

*Professional Instruments  
for Professional Users*

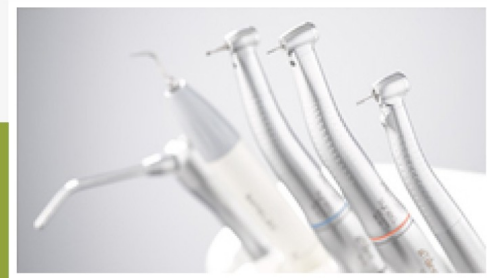

## DENTAL INSTRUMENTS



# AHMED PAK IMPEX

AHMED BUILDING SAMINAR ROAD, NEKA PURA, SIALKOT 51310 PAKISTAN.

+92 321 7131515

info@ahmedpak.com | Zee.ahmedpak@gmail.com

www.ahmedpak.com

# Extracting Forceps "English Pattern" Tungsten Carbide Inserts



**1001**  
Fig. 4  
lower incisor



**1001**  
Fig. 4  
lower incisor



**1002**  
Fig. 8  
lower premolar



**1040**  
Fig. 39L  
upper molars left  
for children  
**1002**  
Fig. 8  
lower premolar

# Extracting Forceps "English Pattern"



**1003**  
Fig. 1  
upper centrals & canines



**1004**  
Fig. 2  
upper laterals & canines



**1005**  
Fig. 3  
upper incisors & canines



**1006**  
Fig. 4  
upper incisors & canines



**1007**  
Fig. 7  
upper premolars



**1008**  
Fig. 8  
lower premolars



**1009**  
Fig. 13  
lower pre



Ahmed Pak Impex

## Extracting Forceps "English Pattern"



**1010**  
Fig. 13S  
lower premolars  
for children.

**1011**  
Fig. 17  
upper molars, right

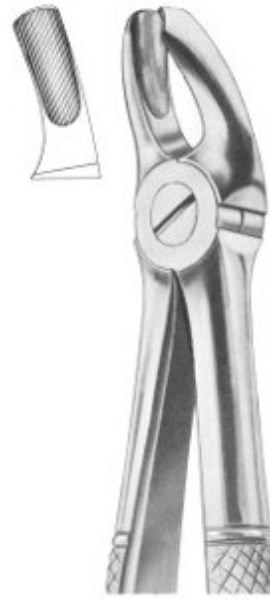

**1012**  
Fig. 18  
upper molars, left

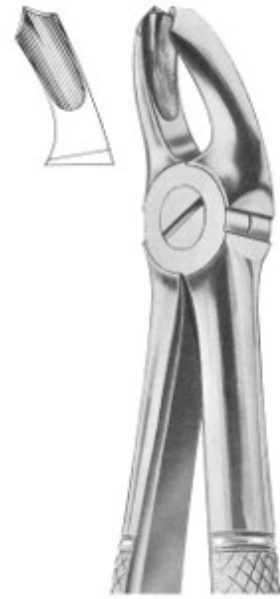

**1013**  
Fig. 18A  
upper molars



**1014**  
Fig. 18B  
upper molars



**1015**  
Fig. 19  
upper third molars

# Extracting Forceps "English Pattern"



**1016**  
Fig. 20  
upper third molars

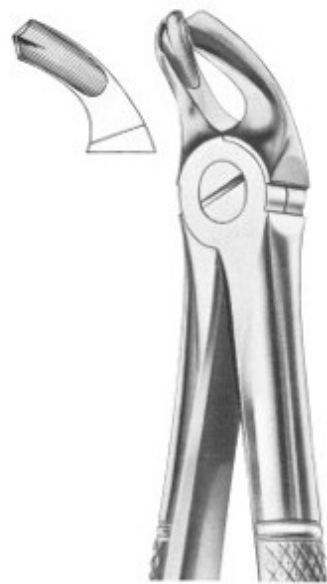

**1017**  
Fig. 21  
lower molars

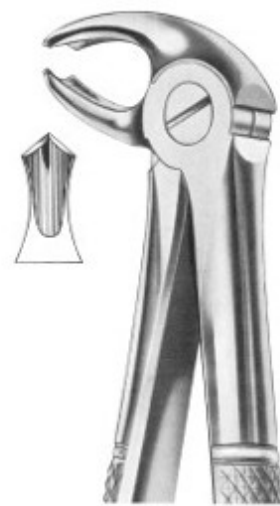

**1018**  
Fig. 22  
lower molars



**1019**  
Fig. 22S  
lower molars  
for children

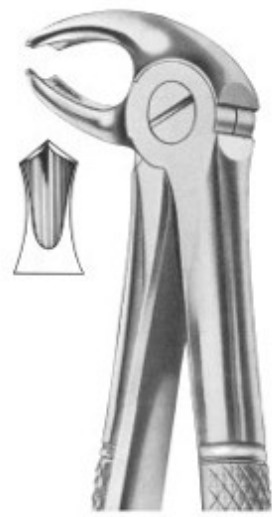

**1020**  
Fig. 22G  
lower molars



**1021**  
Fig. 23  
lower molars right



**1022**  
Fig. 24  
lower molars left



Ahmed Pak Impex

## Extracting Forceps "English Pattern"



**1023**  
Fig. 29  
upper roots



**1024**  
Fig. 29S  
upper roots for children



**1025**  
Fig. 30  
upper roots

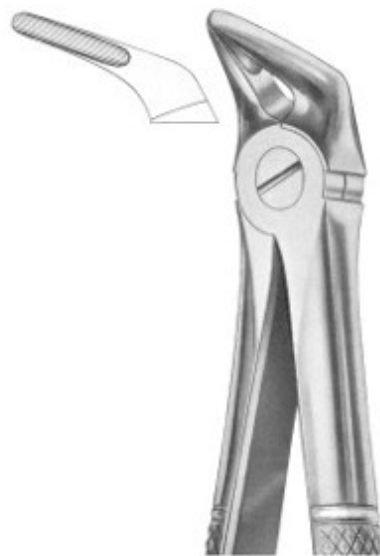

**1026**  
Fig. 31  
lower roots



**1027**  
Fig. 32  
lower molars



**1028**  
Fig. 30S  
upper roots  
for children

# Extracting Forceps "English Pattern"



**1029**  
Fig. 33  
lower roots



**1030**  
Fig. 33A  
lower roots



**1031**  
Fig. 33B  
lower roots



**1032**  
Fig. 33L  
lower roots



**1033**  
Fig. 37  
upper incisors  
for children



**1034**  
Fig. 33S  
lower roots  
for children



Ahmed Pak Impex

## Extracting Forceps "English Pattern"



**1035**  
Fig. 38  
lower incisors &  
canines for children



**1036**  
Fig. 39  
upper molars  
for children



**1037**  
Fig. 39R  
upper molars right  
for children



**1038**  
Fig. 39A  
upper molars  
for children



**1039**  
Fig. 40  
lower molars  
for children



**1040**  
Fig. 39L  
upper molars left  
for children





Ahmed Pak Impex

## Extracting Forceps "English Pattern"



**1041**  
Fig. 41  
upper roots



**1042**  
Fig. 44  
upper roots



**1043**  
Fig. 45  
lower roots



**1046**  
Fig. 50  
upper roots



**1044**  
Fig. 48  
lower roots



**1045**  
Fig. 49  
upper roots



Ahmed Pak Impex

## Extracting Forceps "English Pattern"



**1047**  
Fig. 51  
upper roots



**1048**  
Fig. 51A  
upper roots



**1049**  
Fig. 51L  
upper roots



**1050**  
Fig. 52  
upper roots



**1051**  
Fig. 52A  
upper teeth  
and resection



**1052**  
Fig. 51S  
upper roots  
for children



Ahmed Pak Impex

## Extracting Forceps "English Pattern"



**1053**  
Fig. 54  
for separating  
upper molars



**1054**  
Fig. 55  
for separating  
upper molars



**1055**  
Fig. 56  
for separating  
lower molars

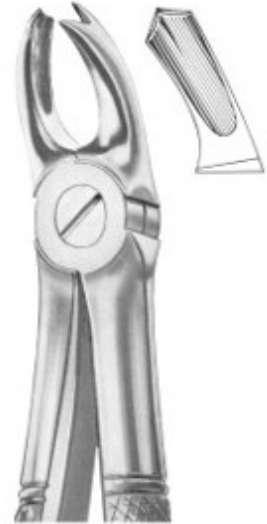

**1056**  
Fig. 65R  
upper molars  
right

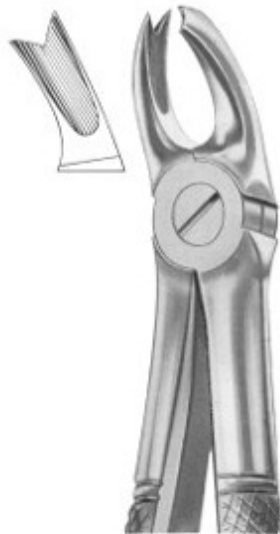

**1057**  
Fig. 65L  
upper molars left



**1058**  
Fig. 67  
upper third molars



**1059**  
Fig. 67A  
upper third

# Extracting Forceps "English Pattern"



**1060**  
Fig. 67 ½R  
upper third molars  
right



**1061**  
Fig. 67 ½L  
upper third molars  
left



**1062**  
Fig. 68  
lower roots



**1063**  
Fig. 68A  
lower roots



**1064**  
Fig. 73  
lower molars



**1065**  
Fig. 73R  
lower molars right



**1066**  
Fig. 73L  
lower m

# Extracting Forceps "English Pattern"



**1067**  
Fig. 73A  
lower molars



**1068**  
Fig. 73S  
lower molars



**1069**  
Fig. 73B  
lower molars for children



**1072**  
Fig. 73K  
lower molars  
for children



**1070**  
Fig. 74  
lower roots



**1071**  
Fig. 74D  
lower roots

# Extracting Forceps "English Pattern"



**1073**  
Fig. 74M  
lower roots



**1074**  
Fig. 74N  
lower roots



**1075**  
Fig. 74XN  
lower roots and  
crowded incisors



**1078**  
Fig. 76N  
upper roots



**1076**  
Fig. 75  
lower premolars



**1077**  
Fig. 76  
upper roots

# Extracting Forceps "English Pattern"



**1079**  
Fig. 76S  
upper roots



**1080**  
Fig. 79  
lower third molars



**1081**  
Fig. 79A  
lower third molars



**1082**  
Fig. 81  
lower premolars  
and roots

# Extracting Forceps "English Pattern"



**1083**  
Fig. 86A  
lower molars



**1084**  
Fig. 86B  
lower molars



**1085**  
Fig. 86C  
lower molars



**1086**  
Fig. 87  
lower molars



**1087**  
Fig. 91  
for separating  
lower molars



**1088**  
Fig. 99  
lower molars



# Extracting Forceps "English Pattern"



**1089**  
Fig. 101  
upper premolars  
and roots



**1090**  
Fig. 100  
upper roots



**1091**  
Fig. 99 1/4  
lower molars



**1092**  
Fig. 99 1/2  
lower molars

# Extracting Forceps "English Pattern"



**1093**  
Fig. 102  
upper molars right



**1094**  
Fig. 103  
upper molars left



**1095**  
Fig. 105  
lower incisors



**1096**  
Fig. 106  
lower incisors



**1097**  
Fig. 103  
upper canines

# Extracting Forceps "English Pattern"



**1098**  
Fig. 112  
upper roots



**1099**  
Fig. 113  
upper roots



**1101**  
Fig. 136  
upper premolars  
and roots



**1102**  
Fig. 137  
lower incisors  
and roots



**1100**  
Fig. 114  
upper roots



**1103**  
Fig. 143  
lower roots



Ahmed Pak Impex

## Extracting Forceps "English Pattern"

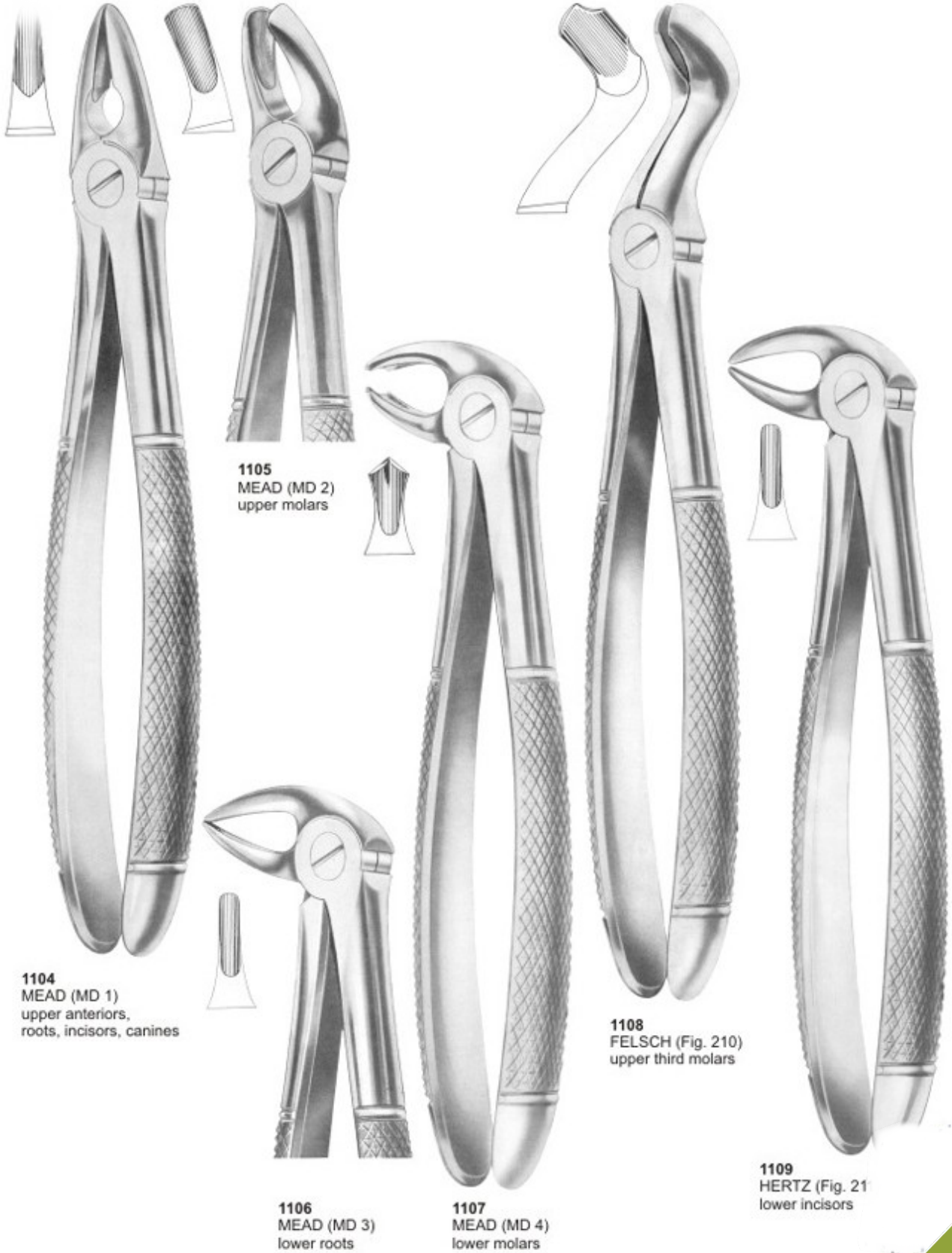



Ahmed Pak Impex

## Wisdom Extracting Forceps



**1110**  
ROUTURIER (Fig. 212)  
( 22 ½ L )  
lower molars  
and wisdom left



**1111**  
ROUTURIER (Fig. 213)  
( 22 ½ R )  
lower molars  
and wisdom right



**1112**  
ROUTURIER (Fig. 214)  
( 22 ½ L )  
lower molars  
and wisdom left



**1113**  
ROUTURIER (Fig. 215)  
( 33 ½ R )  
lower molars  
and wisdom right



**1114**  
RESECTION FORCEPS  
( 216/Witzel )  
upper roots

## Extracting Forceps “English Pattern”



1115  
Fig. 5



1116  
Fig. 6

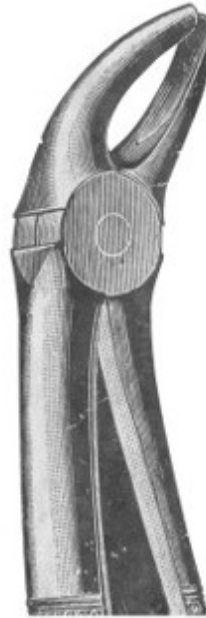

1117  
Fig. 9



1118  
Fig. 10



1119  
Fig. 11



1120  
Fig. 12



1121  
Fig. 14



1122  
Fig. 15



Ahmed Pak Impex

## Extracting Forceps "English Pattern"



1123  
Fig. 25



1124  
Fig. 26

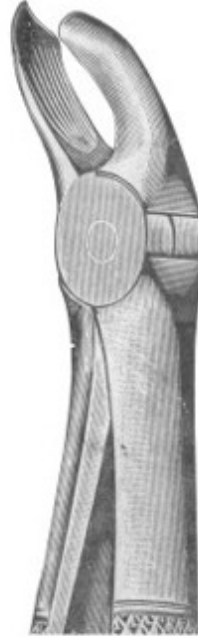

1125  
Fig. 27



1126  
Fig. 28



1127  
Fig. 34



1128  
Fig. 35

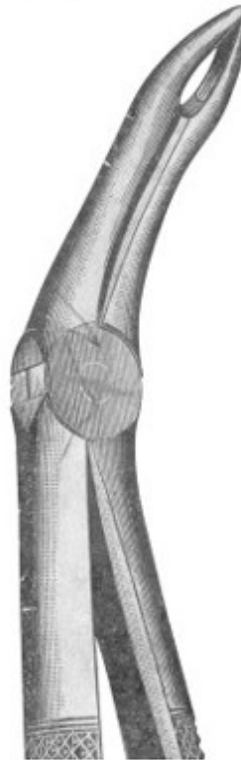

1129  
Fig. 42

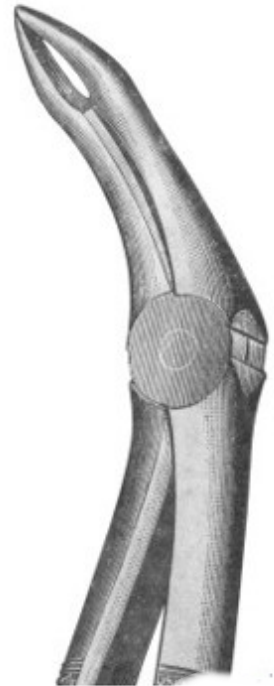

1130  
Fig. 43

# Extracting Forceps "English Pattern"



1131  
Fig. 44A



1132  
Fig. 46

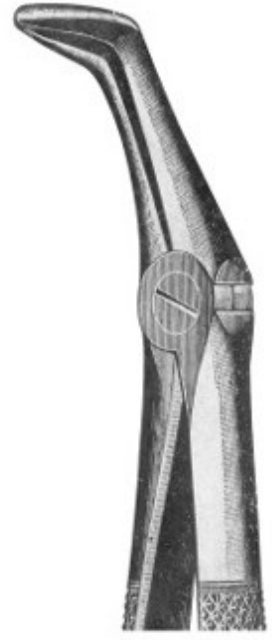

1133  
Fig. 47



1134  
Fig. 50A



1135  
Fig. 74R



1136  
Fig. 74L



1137  
Fig. 75R



1138  
Fig. 75L



# Extracting Forceps "English Pattern"



1139  
Fig. 94



1140  
Fig. 95



1141  
Fig. 98



1142  
Fig. 105



1143  
Fig. 106



1144  
Fig. 2002

# Extracting Forceps "With Fitting Handle"



**1145**  
Fig. 1  
upper laterals  
and canines



**1146**  
Fig. 2  
upper laterals  
and canines



**1147**  
Fig. 3  
upper incisors  
and canines



**1148**  
Fig. 4  
lower incisors  
and canines



**1149**  
Fig. 7  
upper premolars

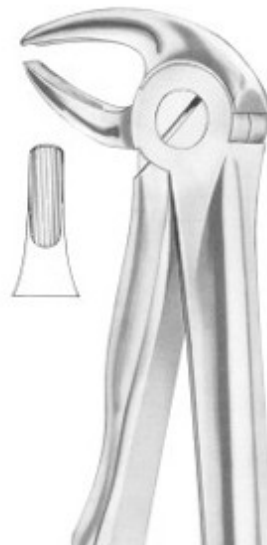

**1150**  
Fig. 13  
lower premolars



**1151**  
Fig. 13S  
lower premolars  
for child



Ahmed Pak Impex

## Extracting Forceps "With Fitting Handle"



**1152**  
Fig. 17  
upper molars right



**1153**  
Fig. 18  
upper molars left



**1154**  
Fig. 18A  
upper molars



**1155**  
Fig. 18B  
upper molars



**1156**  
Fig. 19  
upper third molars



**1157**  
Fig. 22  
lower molars



**1158**  
Fig. 22S  
lower molars  
for

# Extracting Forceps "With Fitting Handle"



**1159**  
Fig. 29  
upper roots



**1160**  
Fig. 29S  
upper roots  
for children

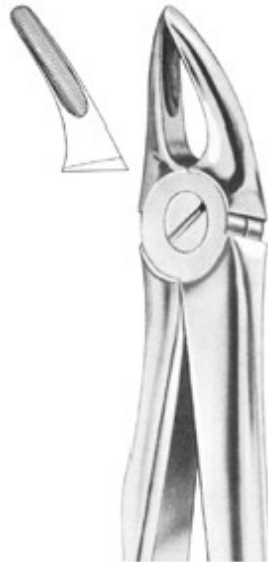

**1161**  
Fig. 30  
upper roots



**1162**  
Fig. 30S  
upper roots  
for children

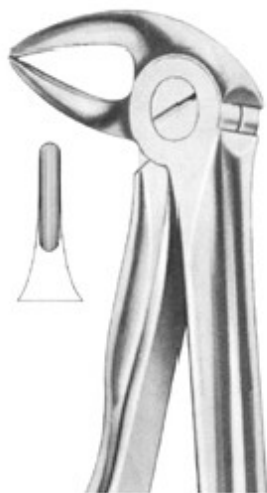

**1163**  
Fig. 33  
lower roots



**1164**  
Fig. 33A  
lower roots

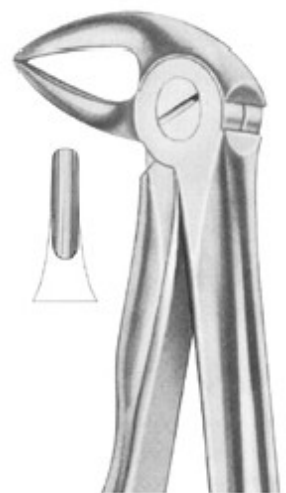

**1165**  
Fig. 33B  
lower roots



Ahmed Pak Impex

## Extracting Forceps "With Fitting Handle"



**1166**  
Fig. 33L  
lower roots



**1167**  
Fig. 33S  
lower roots  
for children



**1168**  
Fig. 37  
upper incisors  
for children



**1169**  
Fig. 39  
upper incisors  
for children



**1170**  
Fig. 39A  
upper molars  
for children



**1171**  
Fig. 39R  
upper molars right  
for children



**1172**  
Fig. 39L  
upper molars left  
for children

# Extracting Forceps "With Fitting Handle"



**1173**  
Fig. 41  
upper roots

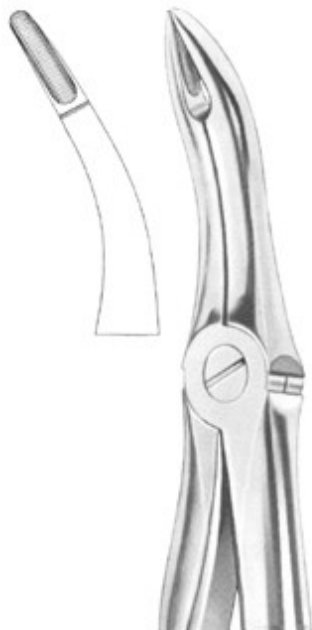

**1174**  
Fig. 44  
upper roots

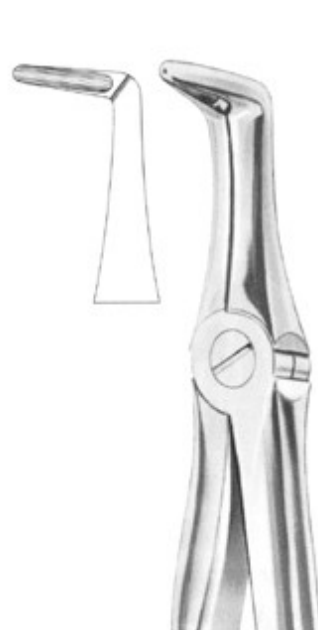

**1175**  
Fig. 45  
lower roots

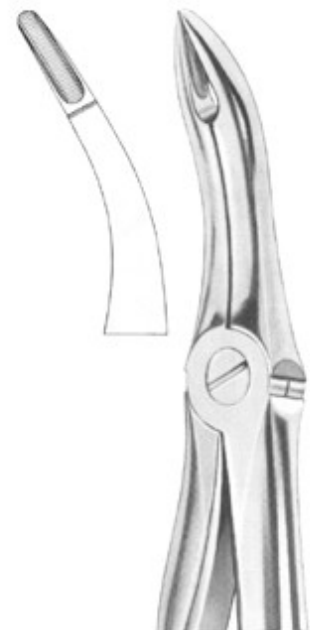

**1176**  
Fig. 48  
lower roots

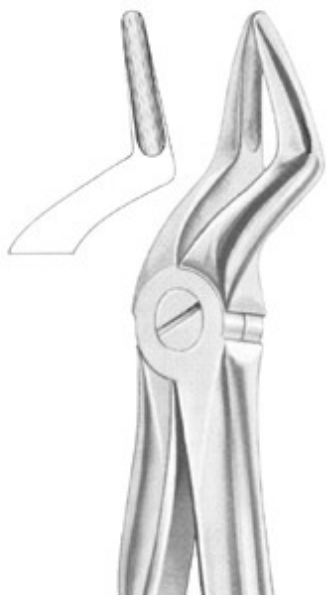

**1177**  
Fig. 51  
upper roots



**1178**  
Fig. 51A  
upper roots



**1179**  
Fig. 51S  
upper roots  
for c<sup>h</sup>



Ahmed Pak Impex

## Extracting Forceps "With Fitting Handle"



**1180**  
Fig. 51L  
upper roots

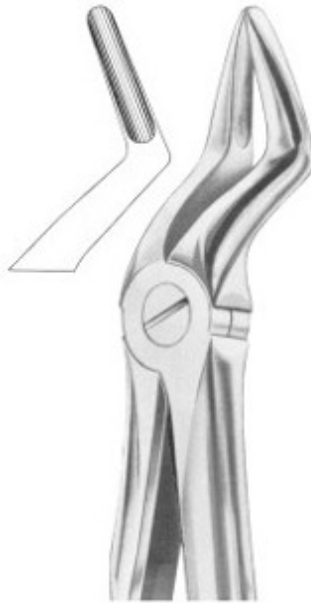

**1181**  
Fig. 52  
upper roots



**1182**  
Fig. 54  
for separating  
upper molars



**1183**  
Fig. 65R  
upper molars right



**1184**  
Fig. 65L  
upper molars left



**1185**  
Fig. 67  
upper third molars

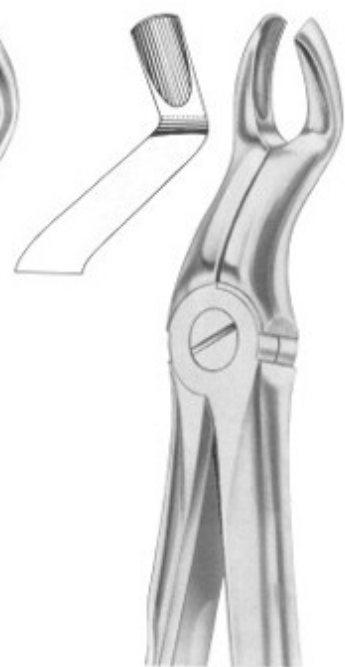

**1186**  
Fig. 67A  
upper third

# Extracting Forceps "With Fitting Handle"



**1187**  
Fig. 67 ½ R  
upper third molars  
right



**1188**  
Fig. 67 ½ L  
upper third molars  
left



**1189**  
Fig. 73  
lower molars



**1190**  
Fig. 74  
lower roots



**1191**  
Fig. 74M  
lower roots



**1192**  
Fig. 74N  
lower roots



**1193**  
Fig. 74XN  
lower roots and  
crowded incisors





Ahmed Pak Impex

## Extracting Forceps "With Fitting Handle"



**1194**  
Fig. 75  
lower premolars



**1195**  
Fig. 76  
upper roots



**1196**  
Fig. 76N  
upper roots



**1197**  
Fig. 81  
lower premolars  
and roots



**1198**  
Fig. 76A  
lower third molars



**1199**  
Fig. 79  
lower third molars

# Extracting Forceps "With Fitting Handle"



**1200**  
Fig. 86A  
lower molars



**1201**  
Fig. 86B  
lower molars



**1202**  
Fig. 86C  
lower molars



**1203**  
Fig. 99  
lower molars



**1204**  
Fig. 99 1/4  
lower molars



**1205**  
Fig. 136  
upper premolars  
and roots



**1206**  
Fig. 143  
lower roots



Ahmed Pak Impex

## Extracting Forceps "For Children"



**1207**  
KLEIN (Fig. 217)  
upper incisors



**1208**  
KLEIN (Fig. 218)  
upper premolars



**1209**  
KLEIN (Fig. 219)  
upper roots



**1210**  
KLEIN (Fig. 220)  
upper molars



**1211**  
KLEIN (Fig. 221)  
lower incisors



**1212**  
KLEIN (Fig. 222)  
lower molars



**1213**  
KLEIN (Fig. 223)  
lower roots



**1214**  
ALBRECHT  
Fig. 224  
Deciduous



**1215**  
ALBRECHT  
Fig. 225  
Deciduous



Ahmed Pak Impex

# Root Splinter Forceps

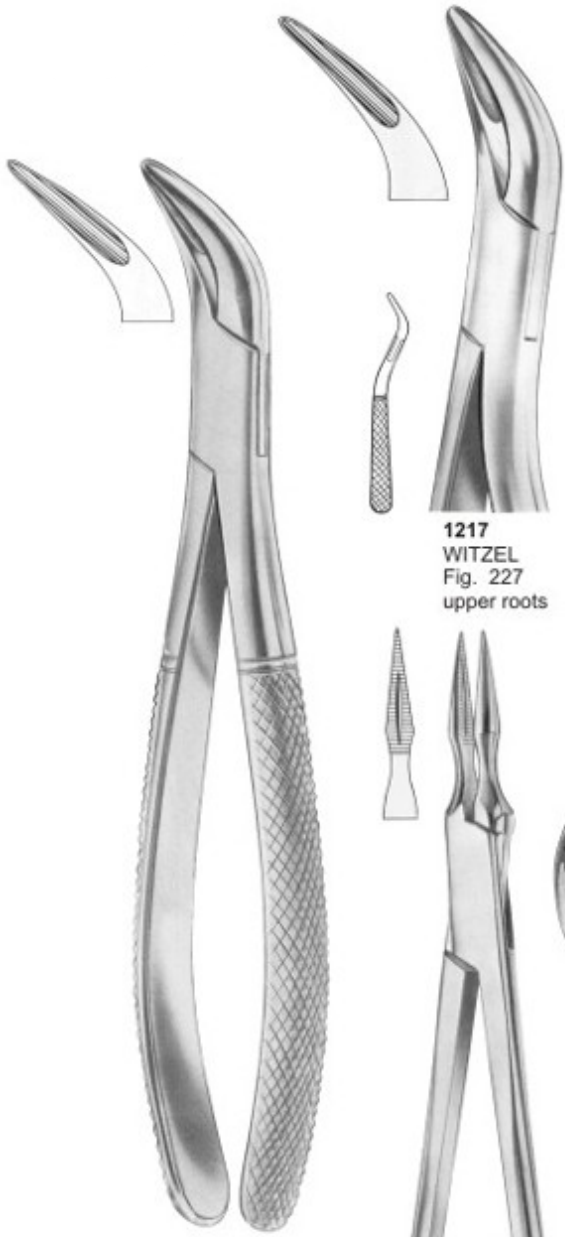

**1217**  
WITZEL  
Fig. 227  
upper roots



**1219**  
STIEGLITZ  
Fig. 229  
root fragments



**1220**  
STIEGLITZ  
Fig. 230  
root fragments



**1218**  
ARTHUR  
Fig. 228  
root fragments



**1221**  
RALK  
Fig. 231  
root fragment

**1216**  
WITZEL  
Fig. 226  
lower roots



Ahmed Pak Impex

## Extracting Forceps "American Pattern"



**1222**  
W1-WINTER  
upper centrals  
and canines



**1223**  
Fig. 1  
upper incisors and roots

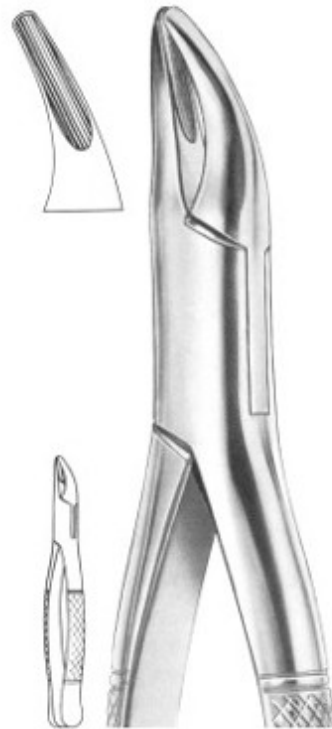

**1224**  
Fig. 2  
upper and lower roots



**1225**  
Fig. 4  
upper and lower premolars

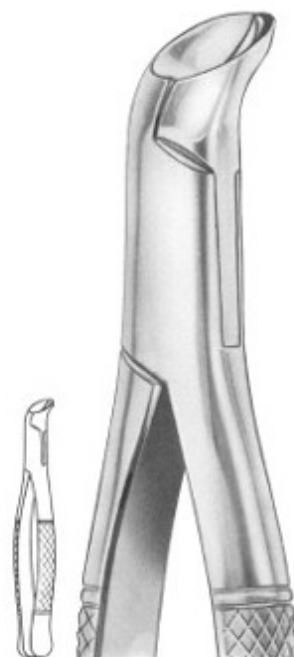

**1226**  
PHYSICK  
Fig. 5  
lower third molars



**1227**  
Fig. 6  
separatrix  
forceps



Ahmed Pak Impex

## Extracting Forceps "American Pattern"



**1228**  
Fig. 7  
upper roots

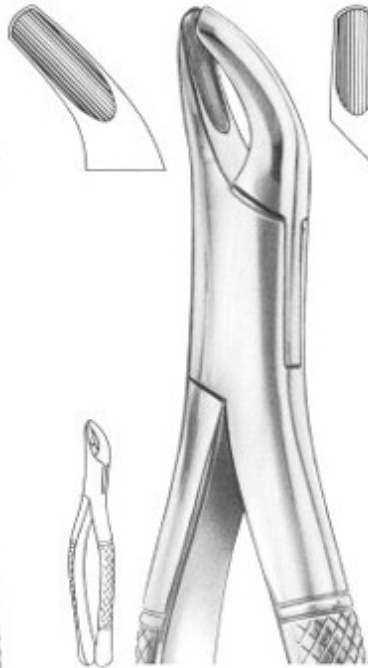

**1229**  
Fig. 8  
upper and lower  
third molars



**1231**  
Fig. 10H  
upper molars



**1232**  
Fig. 13  
upper incisors

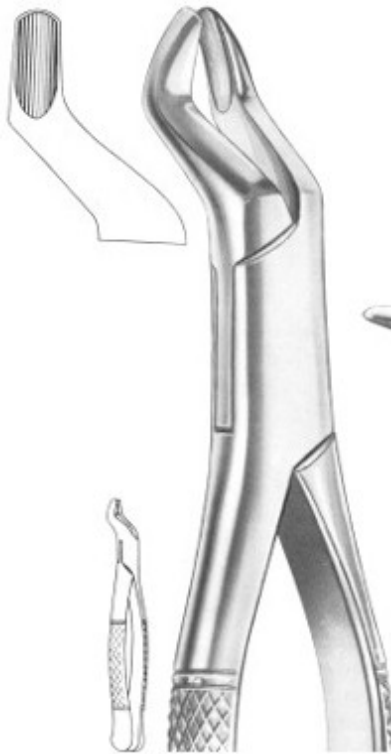

**1230**  
Fig. 10S  
upper molars



**1233**  
Fig. 14  
lower incisors



Ahmed Pak Impex

## Extracting Forceps "American Pattern"



1234  
Fig. 16  
lower molars



1235  
HARRIS  
Fig. 15  
lower molars



1237  
HARRIS  
Fig. 18R  
upper molars right



1238  
HARRIS  
Fig. 18L  
upper molars left



1236  
Fig. 16S  
lower molars  
for children

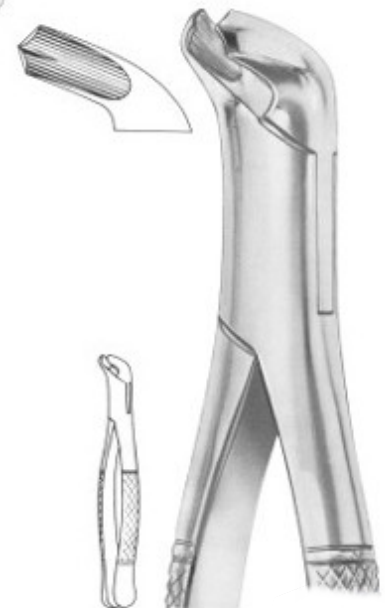

1239  
Fig. 17  
lower molar:



Ahmed Pak Impex

## Extracting Forceps "American Pattern"

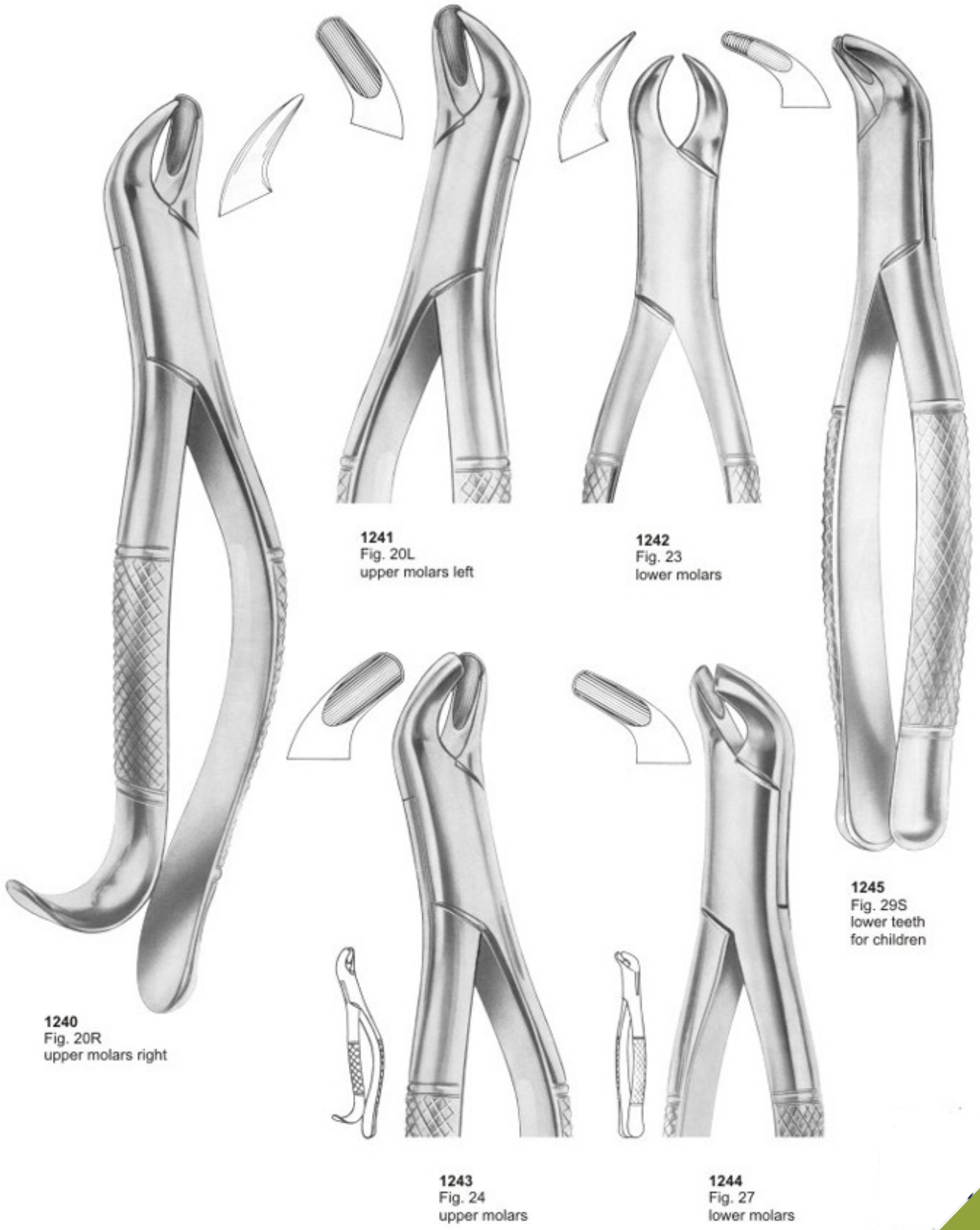





Ahmed Pak Impex

## Extracting Forceps "American Pattern"



**1246**  
Fig. 30S  
upper teeth  
for children



**1247**  
PARMLY  
Fig. 32  
upper premolars  
and molars



**1248**  
PARMLY  
Fig. 32A  
upper premolars  
and roots



**1249**  
Fig. 34  
lower anteriors  
and roots



**1250**  
Fig. 35  
upper roots



**1251**  
Fig. 36  
lower ante-  
and roots



Ahmed Pak Impex

## Extracting Forceps "American Pattern"



**1252**  
Fig. 37  
lower anteriors  
and roots

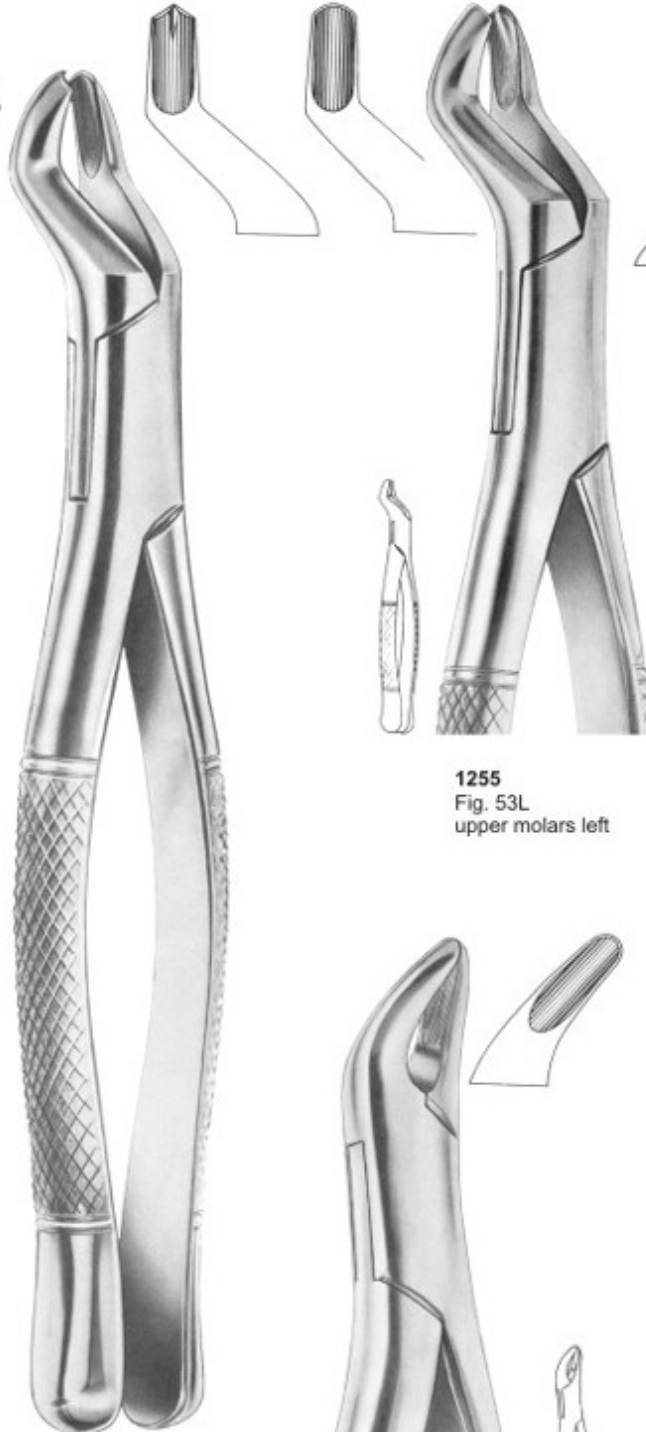

**1254**  
Fig. 53R  
upper molars right

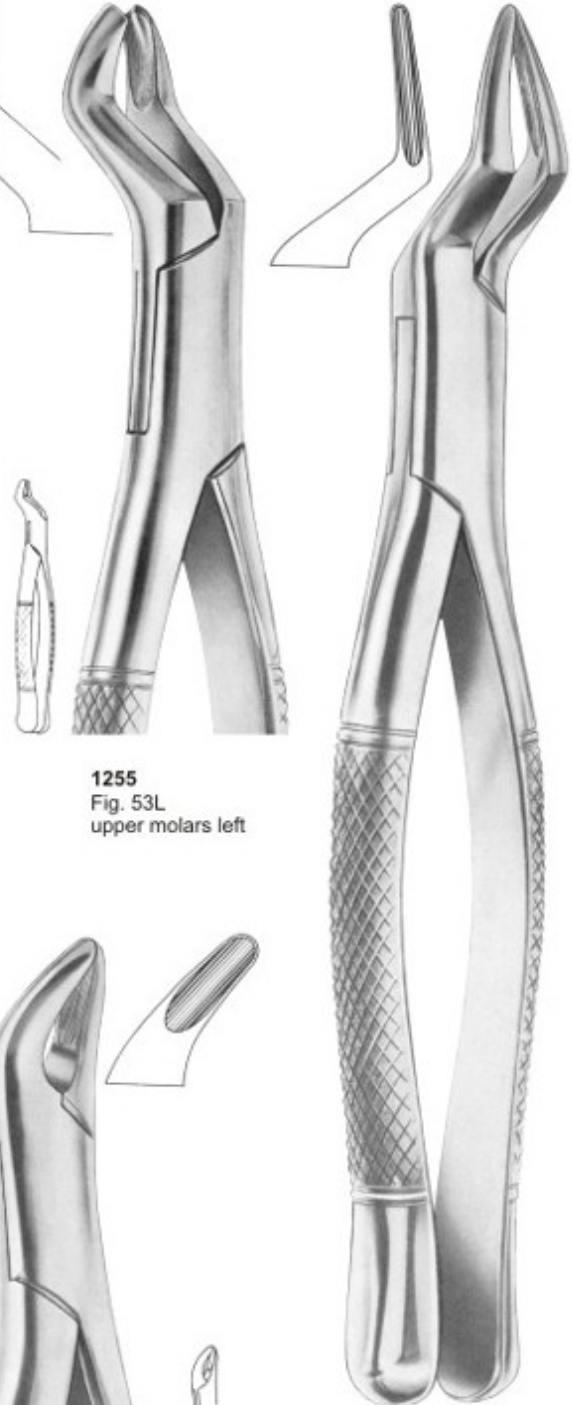

**1255**  
Fig. 53L  
upper molars left



**1253**  
Fig. 38  
upper anteriors



**1256**  
Fig. 62  
incisors, premolars,

**1257**  
Fig. 65  
upper incisors  
and roots

# Extracting Forceps "American Pattern"



**1258**  
TOME'S  
Fig. 69  
upper and lower roots



**1259**  
TOME'S  
Fig. 85  
lower canines,  
premolars and molars

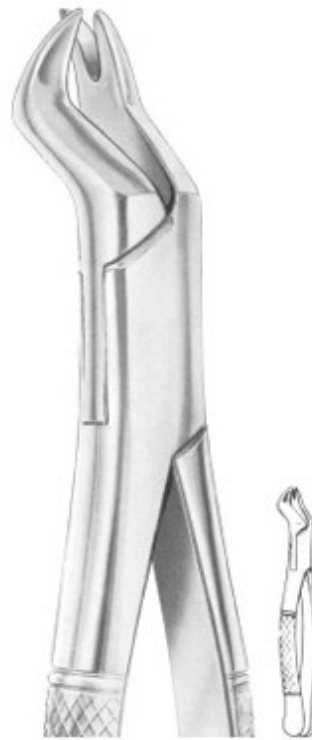

**1260**  
NEVIUS  
Fig. 88R  
upper molars right



**1261**  
THOMAS  
Fig. 85A  
upper molars



**1262**  
NEVIUS  
Fig. 88L  
upper molars



Ahmed Pak Impex

## Extracting Forceps "American Pattern"



**1263**  
KELLS  
Fig. 99A  
upper incisors,  
canines, premolars



**1264**  
Fig. 104  
upper third molars



**1266**  
HULL  
Fig. 101  
deciduous teeth



**1267**  
Fig. 103  
lower incisors,  
premolars



**1265**  
KELLS  
Fig. 99C  
upper incisors,  
canines, premolars



Ahmed Pak Impex

## Extracting Forceps "American Pattern"



**1268**  
CRYER  
Fig. 150  
lower incisors,  
premolars, roots



**1269**  
CRYER  
Fig. 150A  
upper incisors,  
premolars, roots



**1271**  
CRYER  
Fig. 151  
lower incisors,  
premolars, roots



**1272**  
CRYER  
Fig. 151A  
lower incisors,  
premolars, roots



**1270**  
CRYER  
Fig. 150S  
upper teeth for children



**1273**  
CRYER  
Fig. 151S  
lower teeth  
for child



Ahmed Pak Impex

## Extracting Forceps "American Pattern"



**1274**  
Fig. 203  
lower incisors  
and roots

**1275**  
Fig. 210S  
upper third molars

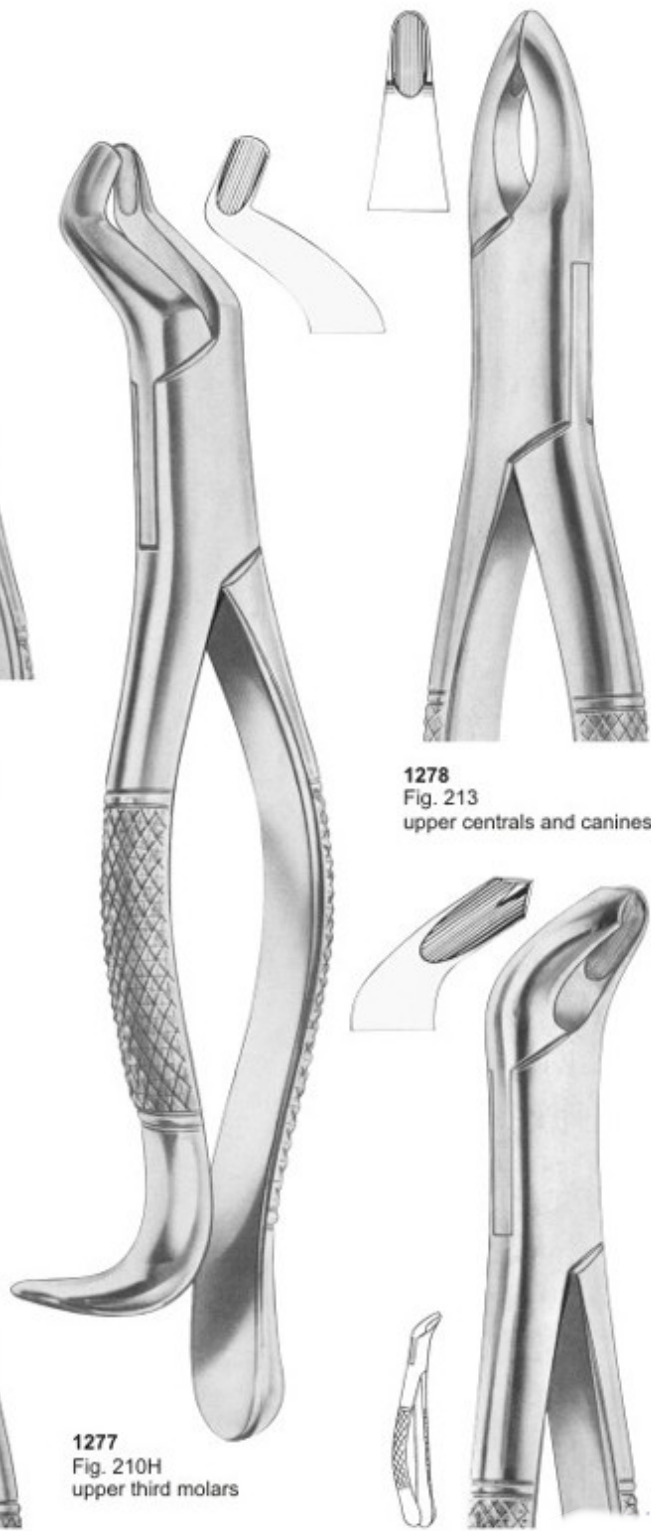

**1276**  
Fig. 201  
upper incisors,  
canines, premolars

**1277**  
Fig. 210H  
upper third molars

**1278**  
Fig. 213  
upper centrals and canines

**1279**  
Fig. 217  
lower m



Ahmed Pak Impex

## Extracting Forceps "American Pattern"

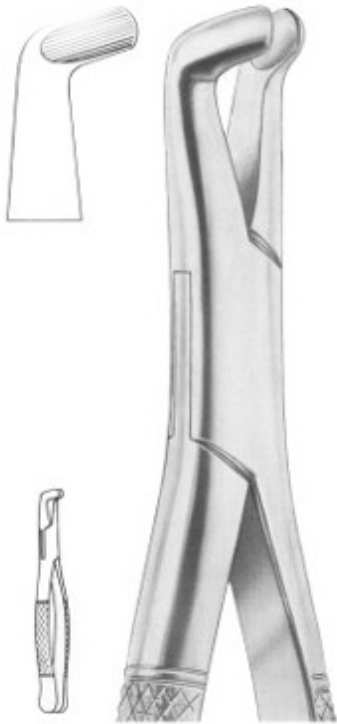

**1280**  
Fig. 222  
lower third molars



**1282**  
Fig. 286  
Swing lower molars



**1283**  
Fig. 288  
lower canines  
and premolars

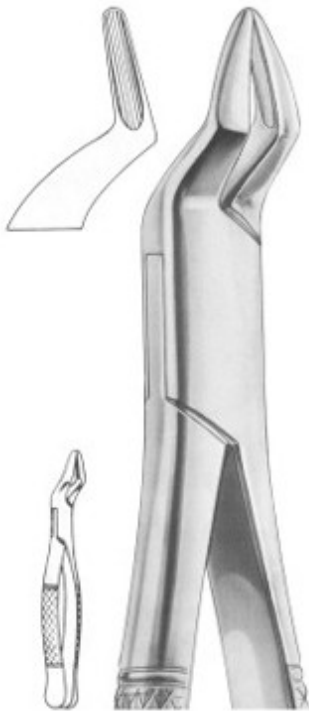

**1281**  
Fig. 286  
upper incisors and roots



Ahmed Pak Impex

## Extracting Forceps "American Pattern"

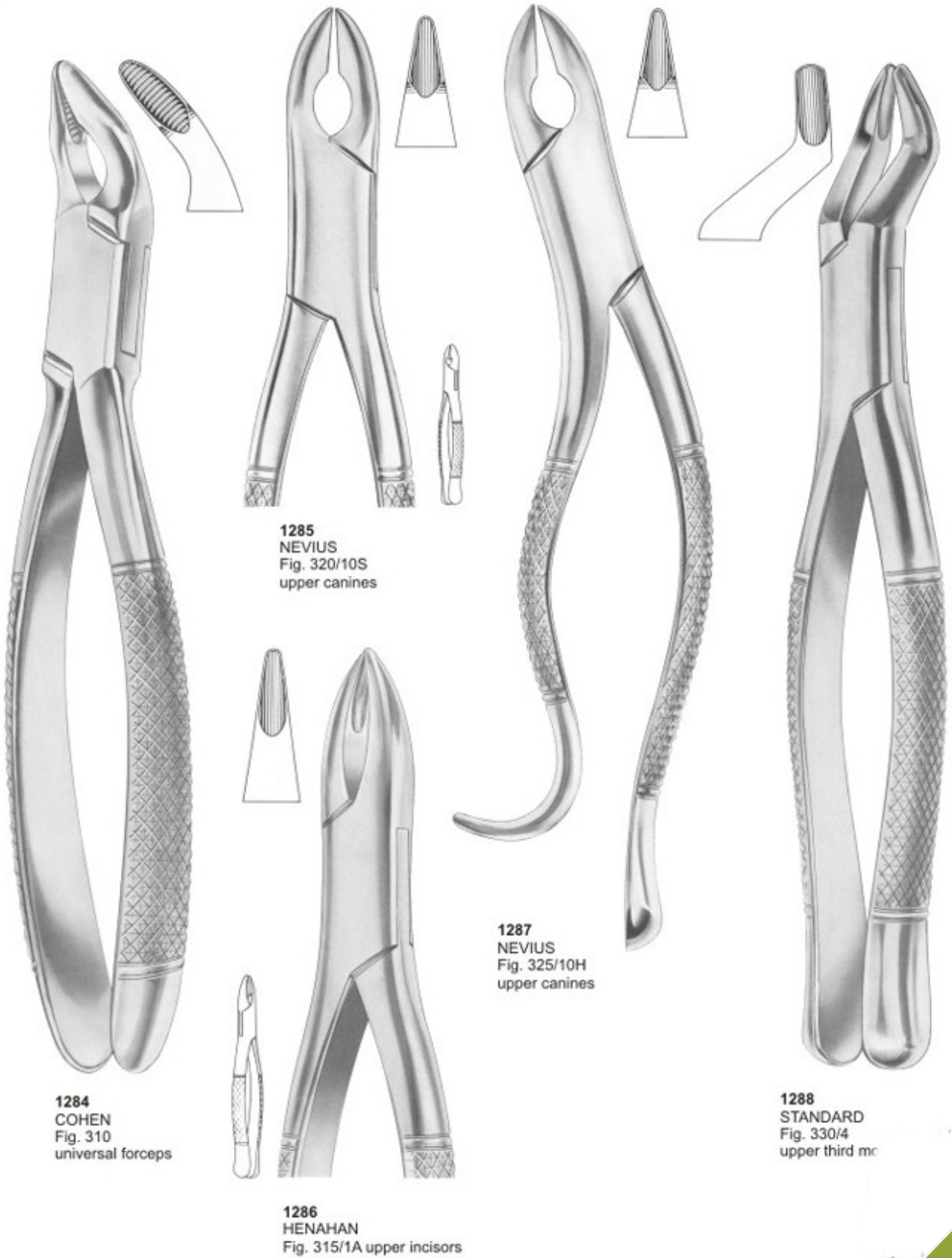



# Extracting Forceps "American Pattern"



**1289**  
WOODWARD  
Fig. 335/FH  
lower molars



**1290**  
Fig. 340/89  
upper molars right



**1292**  
Fig. 345/90  
upper molars left

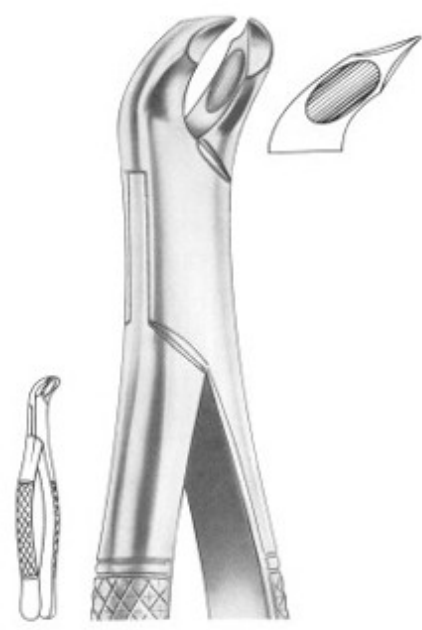

**1291**  
WOODWARD  
Fig. 335/FS  
lower molars



Ahmed Pak Impex

## Forceps For Children "American Pattern"



**1293**  
Fig. 350/23S  
lower molars



**1295**  
Fig. 360/17SK  
lower molars



**1296**  
Fig. 365/150SK  
upper anteriors  
and roots



**1297**  
Fig. 370/151SK  
lower anteriors  
and roots

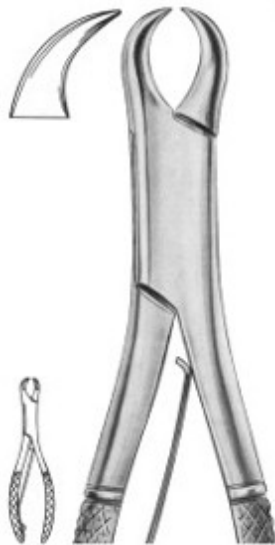

**1294**  
Fig. 355/23SK  
lower molars

# Elevators

## Root Tip



## Heidbrink Root - Tip Picks



# Elevators

## POTTS

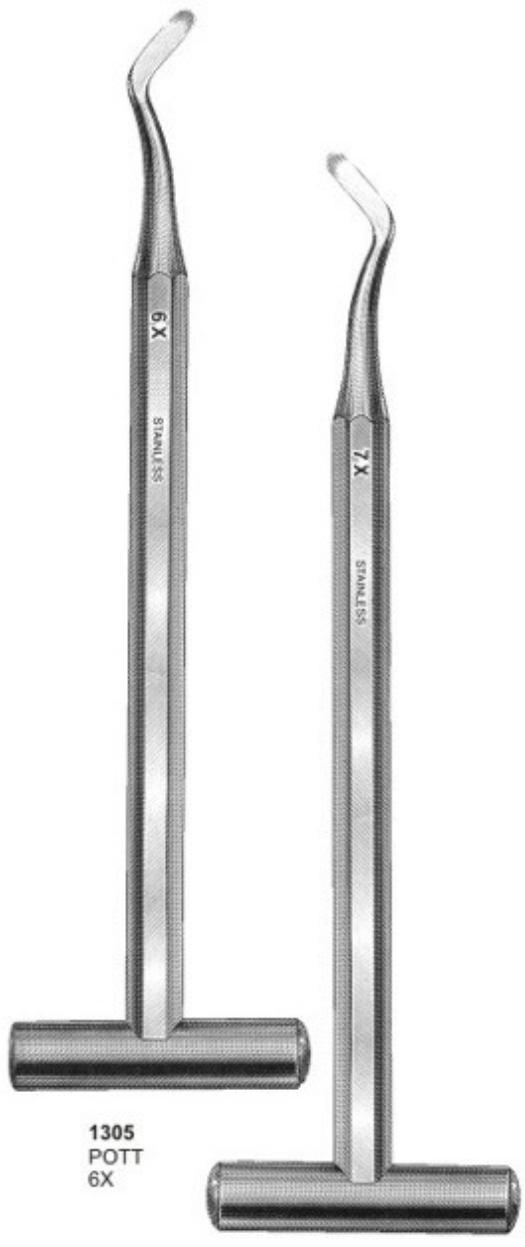

1305  
POTT  
6X

1306  
POTT  
7X

## PERIOSTEAL



1307  
FREER

1308  
WEST  
DEL W2

1309  
DEL OHL

1310  
SELDIN

1311  
MOLT

# Root Elevators

lower jaw, left side

lower jaw, right side



1312



1313

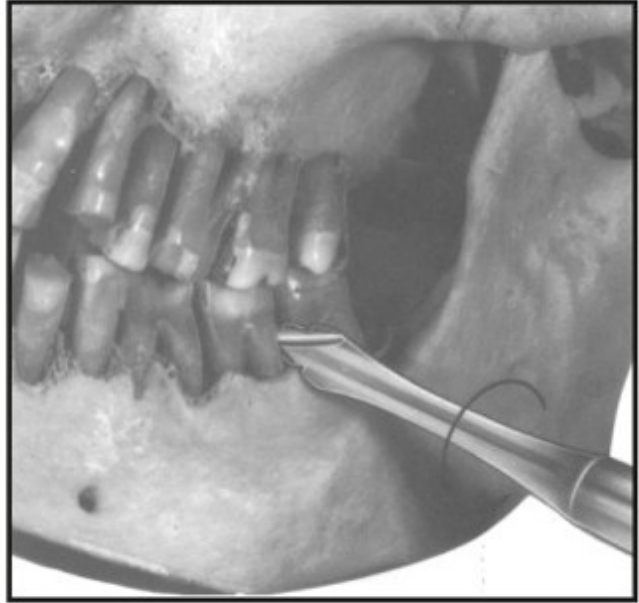

Root elevator, spiral-shaped, for extremely facilitated extraction of the molars in the lower jaw. The slender, conical points allow deep penetration between tooth and gum. Owing to the hook-shaped working parts, slipping of the elevator is avoided.

# Root Elevators



**1314  
BEIN**



**1315  
BEIN  
Fig. 1**



**1316  
BEIN  
Fig. 2**



**1317  
BEIN  
Fig. 0**



**1318  
BEIN  
Fig. 3**



**1319  
BEIN  
Fig. 4**



**1320  
BEIN  
Fig. 5**



**1321  
BEIN  
Fig. 6**



# Root Elevators

Ahmed Pak Impex



1322  
SELDIN



1323  
SELDIN  
Fig. 1L



1324  
SELDIN  
Fig. 1R



1325  
SELDIN  
Fig. 2



1326  
SELDIN  
Fig. 3



1327  
SELDIN  
Fig. 4L



1328  
SELDIN  
Fig. 4R



# Root Elevators

Ahmed Pak Impex



**1329**  
CRYER  
Fig. 3



**1330**  
CRYER  
Fig. 4



**1331**  
CRYER  
Fig. 12



**1332**  
CRYER  
Fig. 27



**1333**  
CRYER  
Fig. 28



**1334**  
CRYER  
Fig. 27S



**1335**  
CRYER  
Fig. 28S



# Root Elevators



1336  
IS-APICAL



1337  
APICAL  
Fig. 1



1338  
APICAL  
Fig. 2



1339  
APICAL  
Fig. 3



1340  
APICAL  
Fig. 4

# Root Elevators



**1341**  
IS-CRYER



**1342**  
CRYER  
Fig. 1



**1343**  
CRYER  
Fig. 2



**1344**  
IS-COUPLAND



**1345**  
COUPLAND  
Fig. 1



**1346**  
COUPLAND  
Fig. 2



**1347**  
COUPLAND  
Fig. 3

# Root Elevators



**1348**  
Fig. 1



**1349**  
Fig. 2



**1350**  
Fig. 3



**1351**  
FLOHR  
Fig. 1



**1352**  
FLOHR  
Fig. 2



**1353**  
FLOHR  
Fig. 3

# Root Elevators



1354  
KOPP  
Fig. 1



1355  
KOPP  
Fig. 2



1360  
KOPP  
Fig. 1



1361  
KOPP  
Fig. 2



1354  
KOPP



1356  
KOPP  
Fig. 3



1357  
KOPP  
Fig. 4



1360  
KOPP



1362  
KOPP  
Fig. 3



1363  
KOPP  
Fig. 4



1358  
KOPP  
Fig. 5



1359  
KOPP  
Fig. 6

# Root Elevators

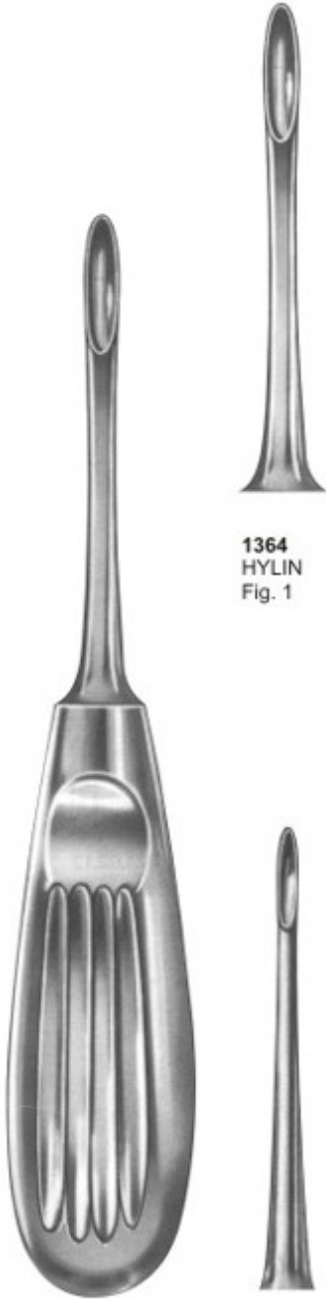

**1364**  
HYLIN



**1364**  
HYLIN  
Fig. 1



**1365**  
HYLIN  
Fig. 2



**1366**  
BEIN



**1366**  
BEIN  
Fig. 1



**1367**  
BEIN  
Fig. 2



**1368**  
BEIN  
Fig. 3

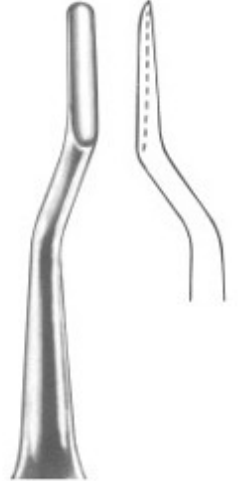

**1369**  
BEIN  
Fig. 4

# Root Elevators



**1370**  
WARWICK-JAMES  
Fig. 1



**1371**  
Warwick-James  
Fig. 2



**1372**  
Warwick-James  
Fig. 3



**1373**  
London-Hospital  
Fig. 1



**1374**  
London-Hospital  
Fig. 2



**1375**  
London-Hospital  
Fig. 3



**1376**  
OTT

# Root Elevators



1377  
Fig. 1



1378  
Fig. 2



1379  
Fig. 1



1380  
Fig. 2

# Root Elevators



**1381**  
CHOMPRET  
Fig. 1



**1382**  
CHOMPRET  
Fig. 2



**1383**  
CHOMPRET  
Fig. 3



**1384**  
CHOMPRET  
Fig. 4



**1385**  
APICAL



# Root Tip Elevators



1386  
IS-Fig. 1



1387  
Fig. 2



1388  
Fig. 3



1389  
HEIDBRINK  
Fig. 1

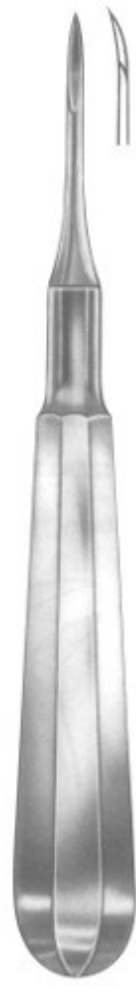

1390  
HEIDBRINK  
Fig. 1



1391  
HEIDBRINK  
Fig. 2



1392  
HEIDBRINK  
Fig. 3

# Root Elevators



**1393**  
MEAD  
MD1

**1394**  
MEAD  
MD-5 A

**1395**  
MEAD  
MD-6 A

**1396**  
MEAD  
MD-7 A

**1397**  
MEAD  
MD-8



**1398**  
LECLUSE



# Root Elevators

Ahmed Pak Impex



**1399**  
WINTER  
Fig. 1L



**1400**  
WINTER  
Fig. 1R



**1401**  
WINTER  
Fig. 2L



**1402**  
WINTER  
Fig. 2R



**1403**  
WINTER  
Fig. 11L



**1404**  
WINTER  
Fig. 11R



**1405**  
WINTER  
Fig. 12L



**1406**  
WINTER  
Fig. 12R

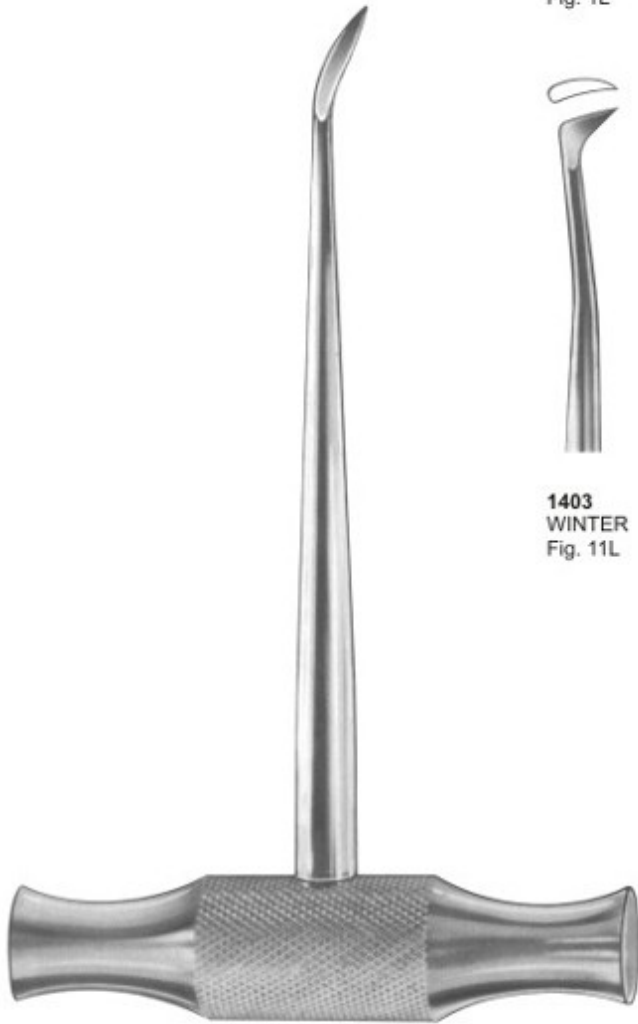

**1399**  
WINTER



**1407**  
WINTER  
Fig. 14L



**1408**  
WINTER  
Fig. 14R

# Root Elevators



**1409**  
BARRY  
Fig. 1



**1410**  
BARRY  
Fig. 2



**1411**  
BARRY  
Fig. 3



**1412**  
BARRY  
Fig. 4



**1409**  
BARRY



**1413**  
BARRY  
Fig. 11



**1414**  
BARRY  
Fig. 12



**1415**  
BARRY  
Fig. 17



**1416**  
BARRY  
Fig. 18

# Root Elevators



**1418**  
CRYER  
Fig. 26



**1419**  
SELDIN  
Fig. 27



**1420**  
CRYER  
Fig. 28



**1421**  
CRYER  
Fig. 29



**1422**  
HEIDBRINK  
Fig. 22



**1423**  
HEIDBRINK  
Fig. 23

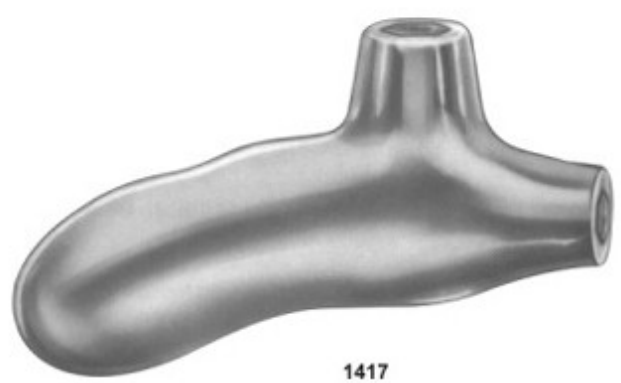

**1417**

# Root Elevators



1425  
KOPP  
Fig. 31



1426  
KOPP  
Fig. 32



1427  
KOPP  
Fig. 33



1428  
KOPP  
Fig. 34



1429  
KOPP  
Fig. 35



1430  
KOPP  
Fig. 44



1424

# Root Elevators



**1432**  
HEIDBRINK  
Fig. 10



**1433**  
WINTER  
Fig. 11



**1434**  
WINTER  
Fig. 12



**1435**  
BARRY  
Fig. 17



**1436**  
BARRY  
Fig. 18



**1437**  
BARRY  
Fig. 20



**1431**

# Root Elevators

Root Elevators according to Dr. Sader, with interchangeable working tips



1439



1438



1440



# Elevators Plastic Handle

1441  
Root Elevator, Plastic Handle, Set of 10 Pcs

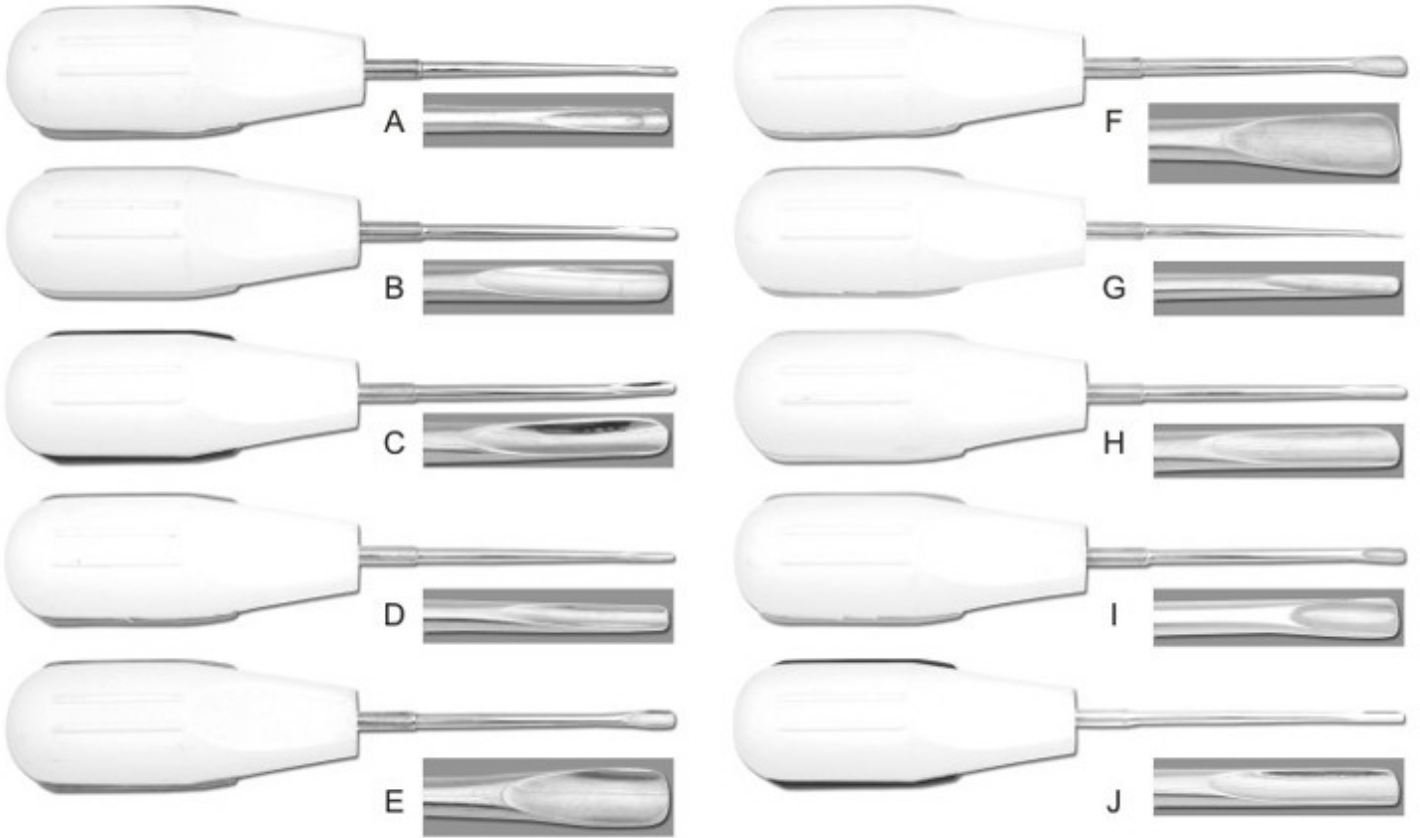

1442  
Root Elevator, Plastic Handle, Set of 5 Pcs

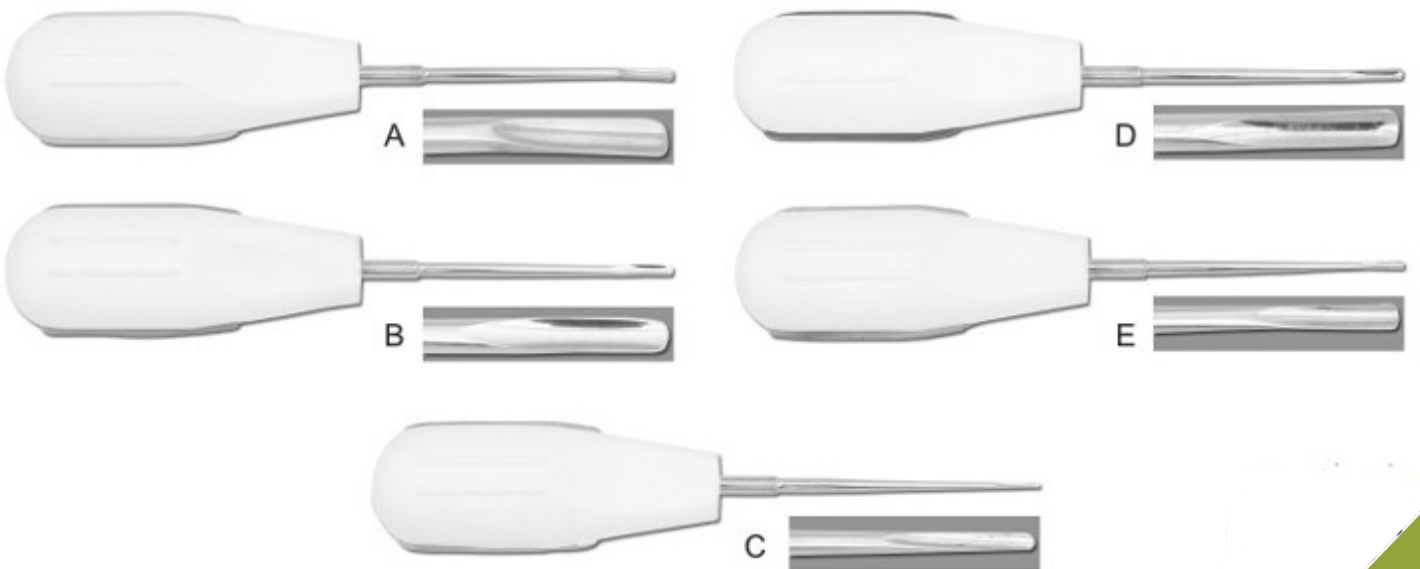

# Scalpel Handles



1443  
Fig. 3L



1444  
Fig. 7



1445  
Fig. 5



1446  
Fig. 5A



1447  
Fig. 3



1448  
Fig. 3G



1449  
Fig. 4

# Handles

Handle For Mouth Mirrors, Probes, Explorers, Excavators, Carvers, Curettes & Scalers



**1450**  
Handle No. 2 (Standard Double Ended)



**1451**  
Handle No. 2 Standard Single Ended



**1452**  
Handle No. 2 Thompson Single Ended



**1453**  
Handle No. 4



**1454**  
Octagonal Double Ended



**1455**  
Octagonal Single Ended



**1456**  
Handle, Double Ended



**1457**  
Double Ended



**1458**  
Handle No. 6 Double Ended



**1459**  
Tactile Tone Double Ended



**1460**  
Tactile Tone Single Ended

# Handles & Mouth Mirrors

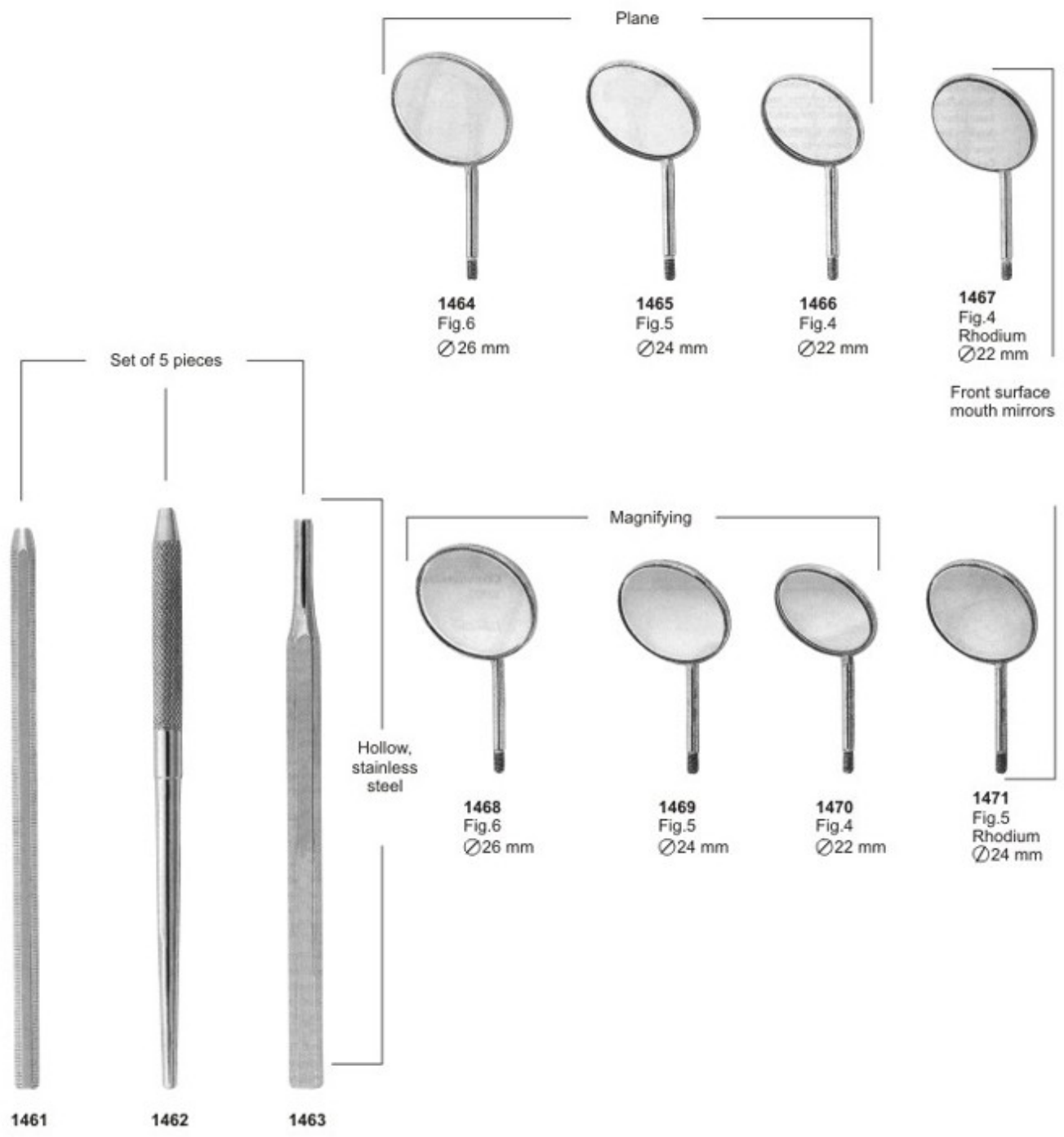

# Mirror Handle, Mouth Mirrors



1472



1473



1474



1475



1476



1477  
Parallelometer  
mouth mirror

1478  
Parallelometer  
mouth mirror  
+ handle  
code 2101

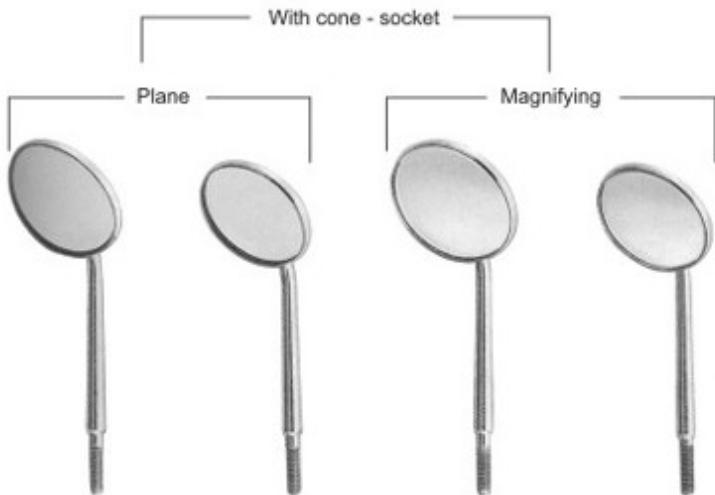

1479  
Fig.5  
Ø24 mm

1480  
Fig.4  
Ø22 mm

1481  
Fig.5  
Ø 24 mm

1482  
Fig.4  
Ø 22 mm



1483  
Cone-socket



1484  
Cone-socket



1485  
Cone

# Scalers

## SCALERS - JAQUETTE

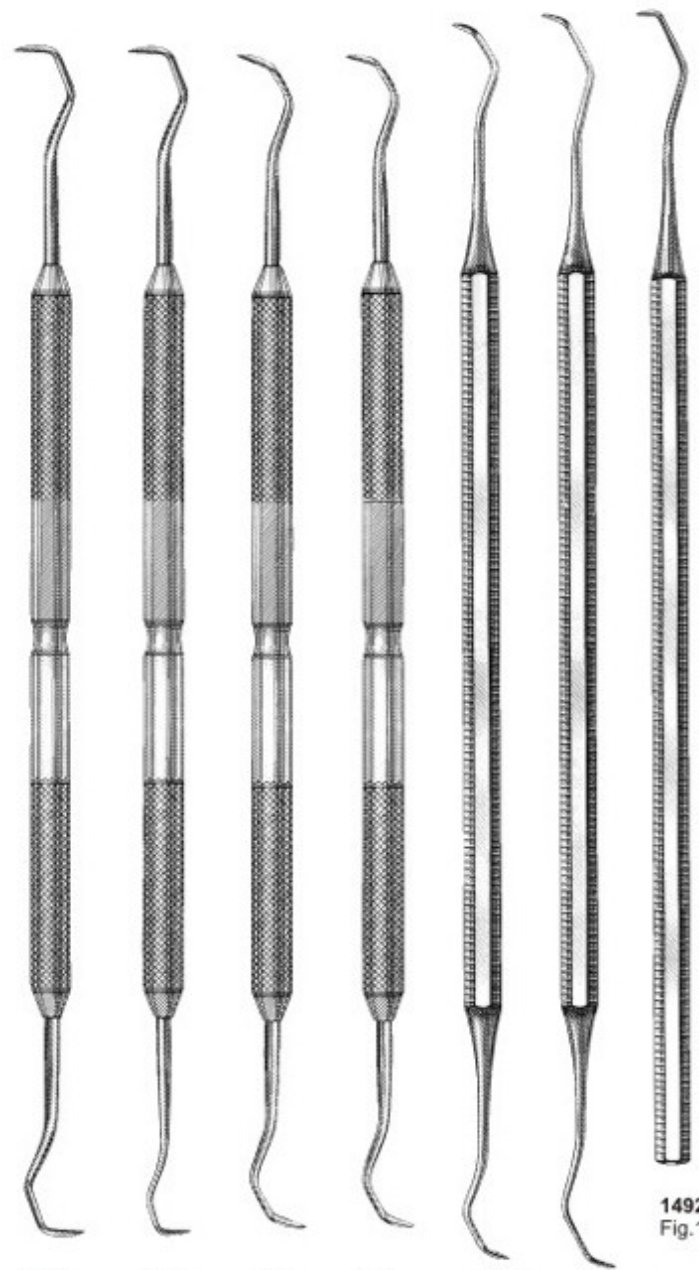

- 1486 1Y-1Y
- 1487 1Y-1YS
- 1488 2Y-3Y
- 1489 2YS-3YS
- 1490 2-3
- 1491 2S-3S

1492 Fig.1

## SCALERS - OCTAGONAL

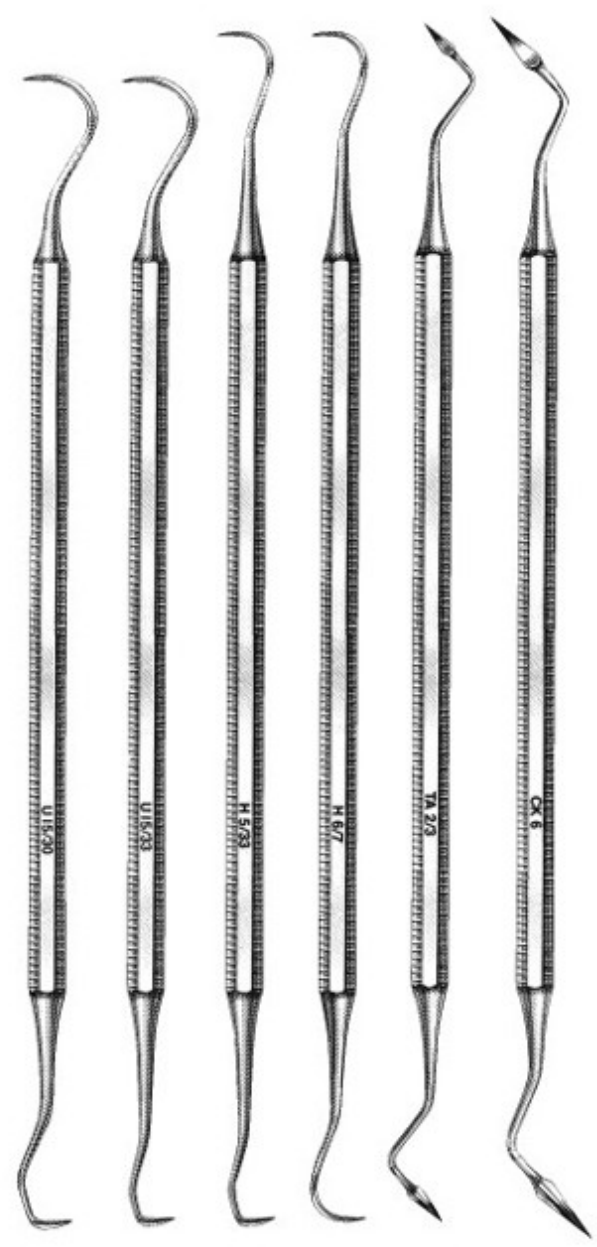

- 1493 U15-30
- 1494 U15-33
- 1495 H5-33
- 1496 H6-7
- 1497 Taylor 2-3
- 1498 CK6

# Scalers



**1499**  
U15



**1500**  
No. 3



**1501**  
No. 12



**1502**  
WHITESIDE 1-0



**1503**  
WHITESIDE 2-0

# Scalers



**1504**  
YAOUNGER/GOOD  
7-8



**1505**  
H5-33



**1506**  
204SD



**1507**  
H6-7

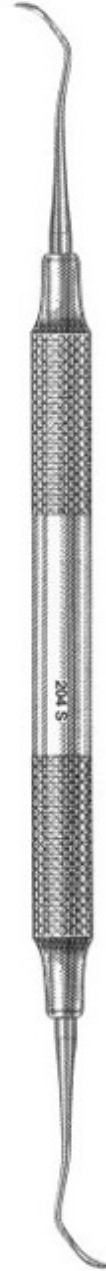

**1508**  
204S



**1509**  
TOWNER/JAQUETTE  
U15-30





# Scalers

Ahmed Pak Impex



1510  
JAQUETTE (33-U15)



1511  
JAQUETTE  
2Y-3Y



1512  
JAQUETTE  
30-U15



1513  
JAQUETTE  
2YS-3YS



1514  
JAQUETTE  
33-H5



1515  
YOUNGER/GOOD  
7-8



1516  
204S



1517  
204SD



1518  
H6-7

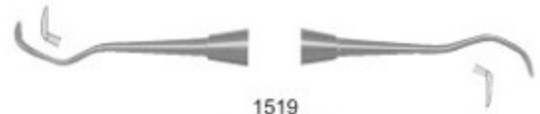

1519  
JAQUETTE  
2S-3S



1520  
JAQUETTE  
1Y-1YS



1521  
JAQUETTE  
2-3



# Burnishers

Ahmed Pak Impex



1794  
21 Acorn



1795  
Fig. 21B



1797  
Fig. 21C



1796  
Fig. 2-34



1798  
Fig. 26-28



1799  
Fig. 2-30



1801  
Fig. 27-29



1800  
Fig. 26-30



1802  
PKT 1



1803  
Fig. 27-30



1805  
Fig. 34T



1804  
PKT 2



1806  
Fig. 3



1807  
PKT 3



1808  
PFI 21



1809  
PKT 3P



1810  
Pitts Pado 19



1811  
PKT 4



1812  
Pitts Pado 18



1813  
PKT 5

# Wax Carvers





# Carvers

Ahmed Pak Impex



**1822**  
1.5mm Cleoid Discoid (Shown with GTX Finish)

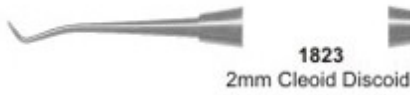

**1823**  
2mm Cleoid Discoid



**1831**  
GOLLOBIN  
Fig. 1



**1824**  
3mm Cleoid Discoid

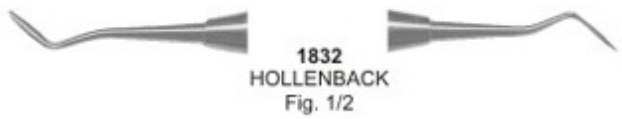

**1832**  
HOLLENBACK  
Fig. 1/2



**1825**  
FRAHM  
Fig. 2-3 (off-angle)

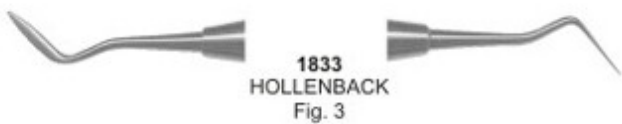

**1833**  
HOLLENBACK  
Fig. 3



**1826**  
Interproximal 1

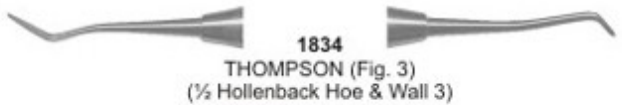

**1834**  
THOMPSON (Fig. 3)  
( $\frac{1}{2}$  Hollenback Hoe & Wall 3)



**1827**  
Interproximal 1



**1835**  
THOMPSON (Fig. 5)  
( $\frac{1}{2}$  Hollenback Hoe & Tanner 5)



**1828**  
Baum Interproximal



**1836**  
THOMPSON (Fig. 8)  
(3mm Cleoid & Wall 3)



**1829**  
Sho A Carver



**1837**  
THOMPSON (Fig. 9)  
(Hollenback 3 & Wall 3)



**1830**  
Thompson 2



**1838**  
WARD  
Fig. 2



# Carvers, Chisels

Ahmed Pak Impex

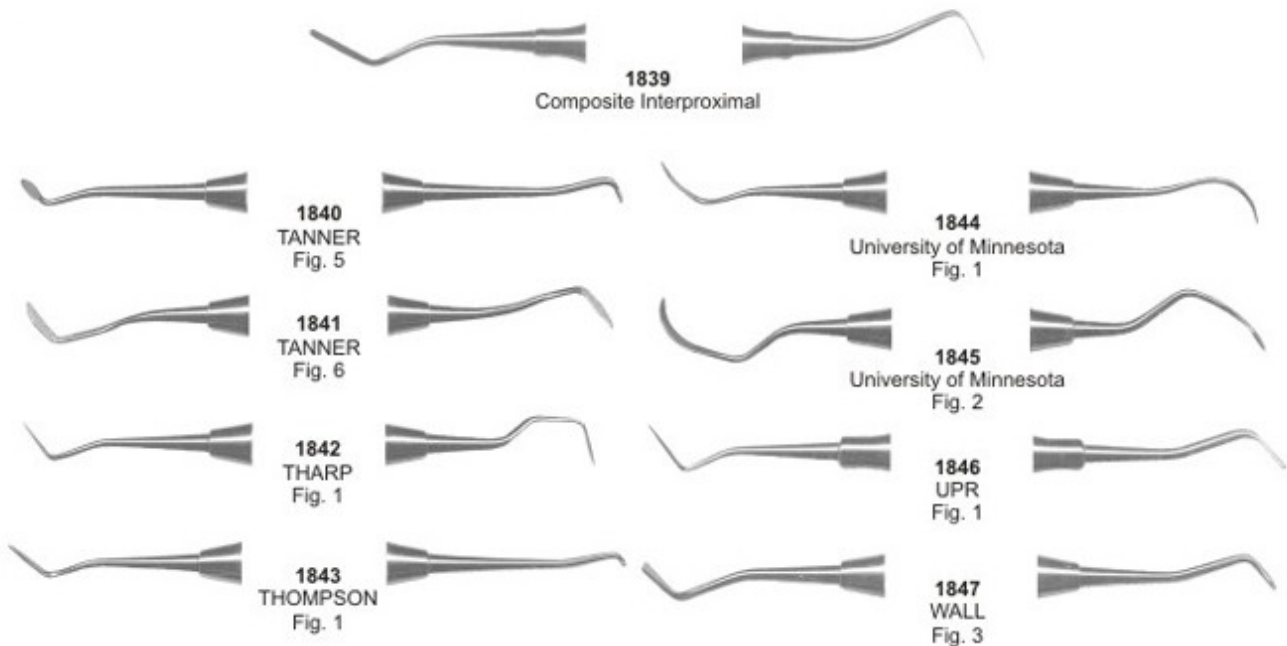

## Contour Carbide Carvers - Finishing

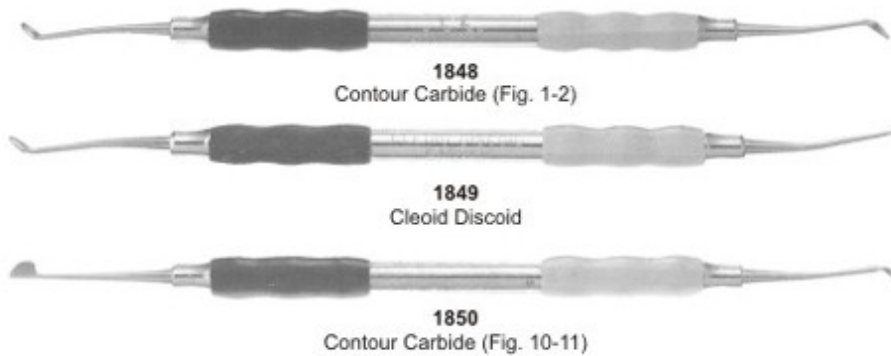

## Chisels

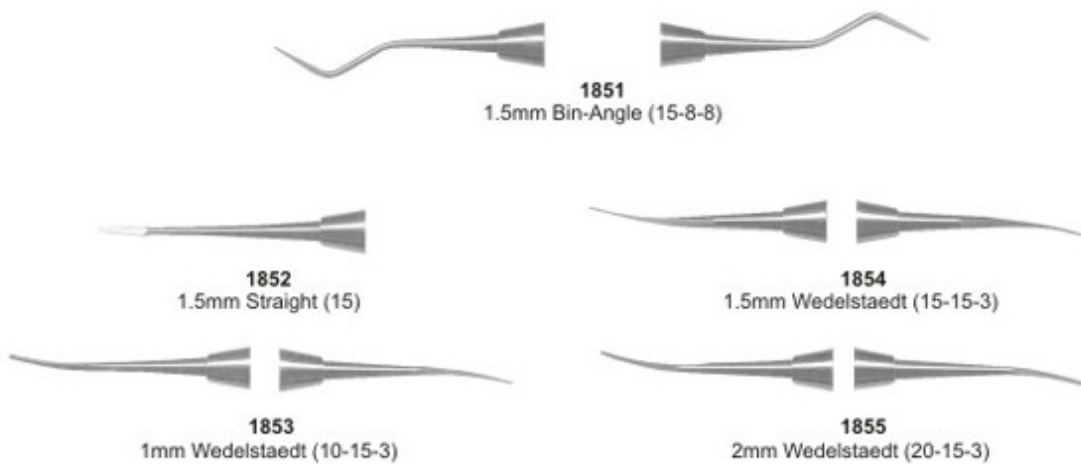

# Composite Placement

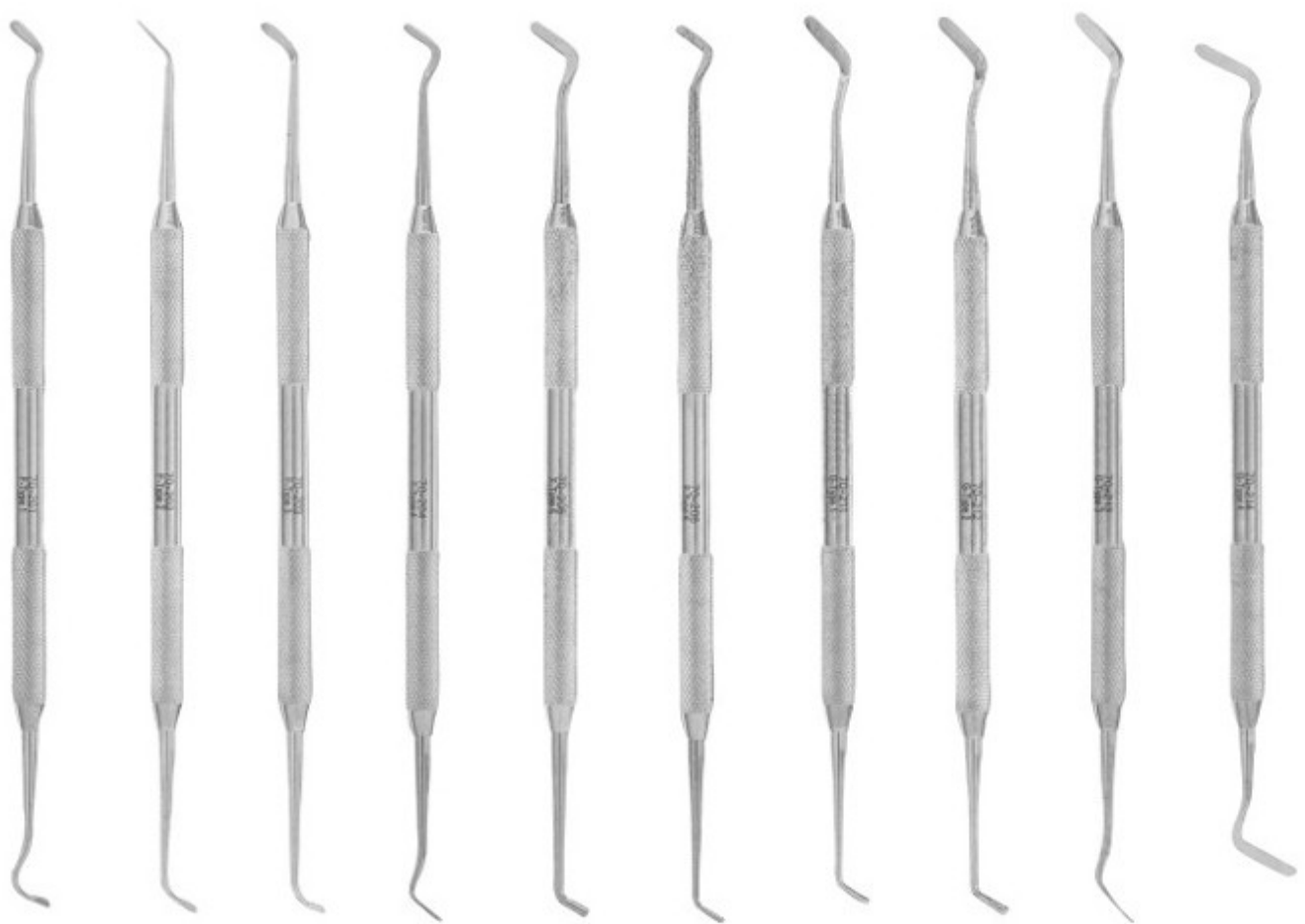

**1856** F-Type 1   
 **1857** F-Type 2   
 **1858** F-Type 3   
 **1859** F-Type 4   
 **1860** F-Type 5   
 **1861** F-Type 6   
 **1862** G-Type 1   
 **1863** G-Type 2   
 **1864** G-Type 3   
 **1865** G-Type 4

# Composite Placement



1866  
Fig. 2

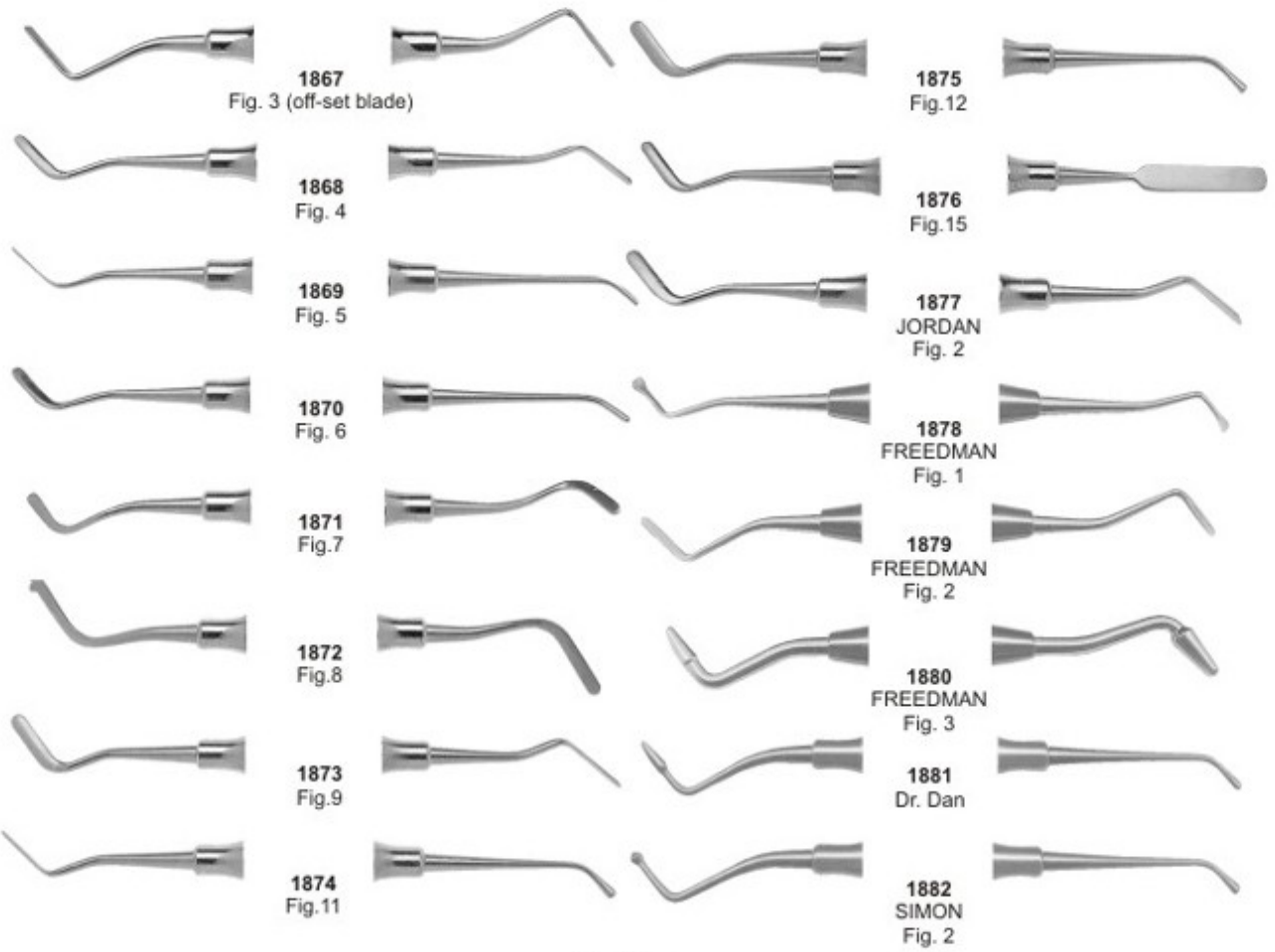

1867  
Fig. 3 (off-set blade)

1875  
Fig.12

1868  
Fig. 4

1876  
Fig.15

1869  
Fig. 5

1877  
JORDAN  
Fig. 2

1870  
Fig. 6

1878  
FREEDMAN  
Fig. 1

1871  
Fig.7

1879  
FREEDMAN  
Fig. 2

1872  
Fig.8

1880  
FREEDMAN  
Fig. 3

1873  
Fig.9

1881  
Dr. Dan

1874  
Fig.11

1882  
SIMON  
Fig. 2

## K - Type

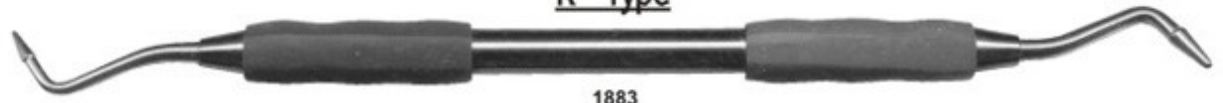

1883  
K-Type 1



1884  
K-Type 2

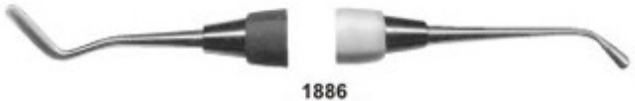

1886  
K-Type 4



1885  
K-Type 3



1887  
K-Type 5



1888  
K-Type 6 Carbide

# Plastic Filling Instruments



1889  
No.3

1890  
No.4

1891  
No.5

1892  
LADMORE  
Fig. 3

1893  
WOODSON  
Fig. 1

1894  
WOODSON  
Fig. 2

1895  
WOODSON  
Fig. 3

1896  
W-3

1897  
Gregg  
4/5



# Plastic Filling Instruments



1898  
Fig. 5-7



1899  
Fig.1



1900  
Fig. 3



1904  
GLICK  
Fig.1



1901  
Fig. 4



1905  
P8



1902  
Fig. 5-7



1906  
WOODSON  
Fig. 1



1903  
Fig. 8A



1907  
WOODSON  
Fig. 2



1908  
WOODSON  
Fig. 3



# Curettes

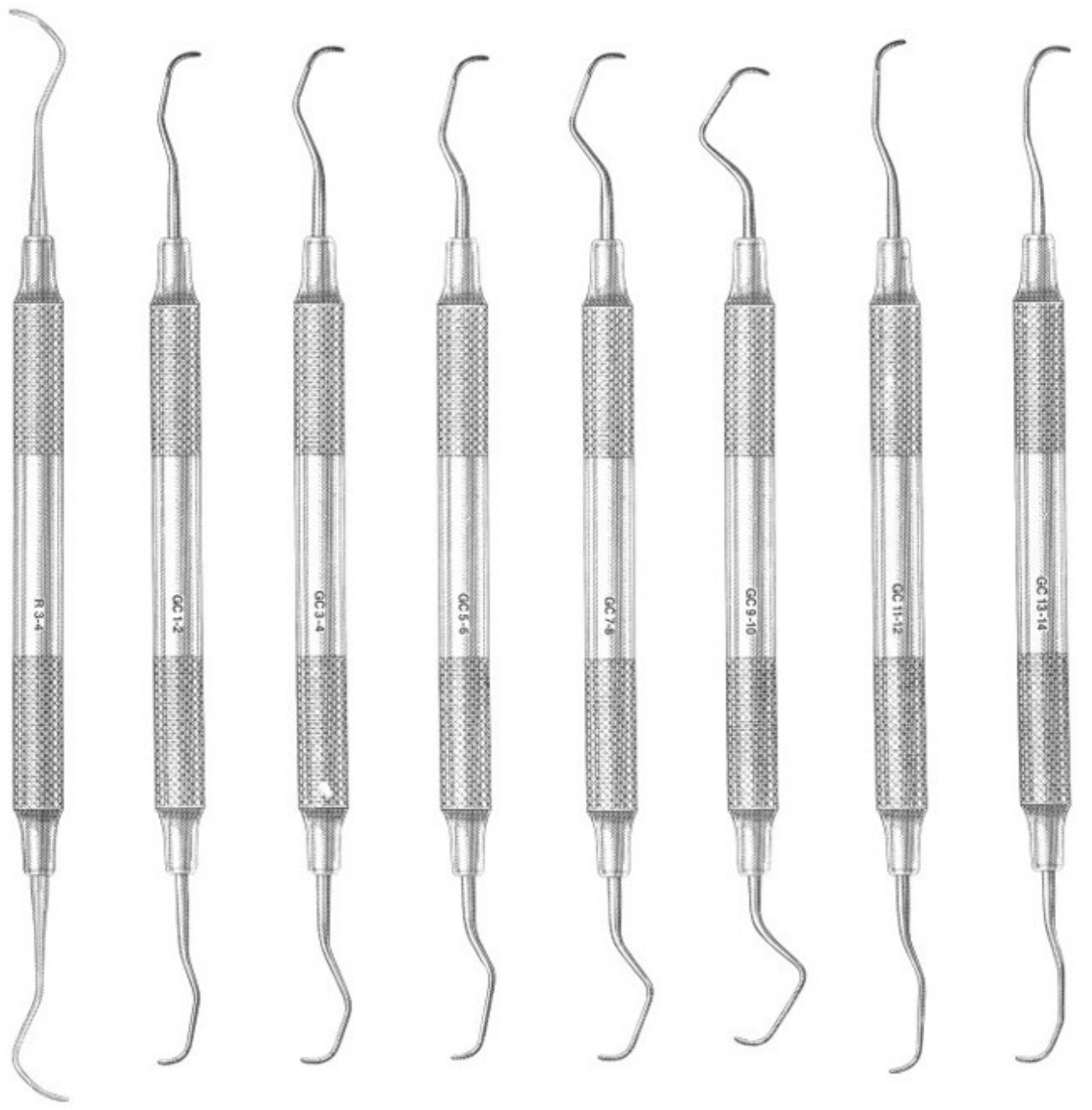

**1909**  
RULE  
3-4

**1910**  
GRACEY  
GC 1-2

**1911**  
GRACEY  
GC 3-4

**1912**  
GRACEY  
GC 5-6

**1913**  
GRACEY  
GC 7-8

**1914**  
GRACEY  
GC 9-10

**1915**  
GRACEY  
GC 11-12

**1916**  
GRACEY  
GC 13-14

# Gracey Currettes

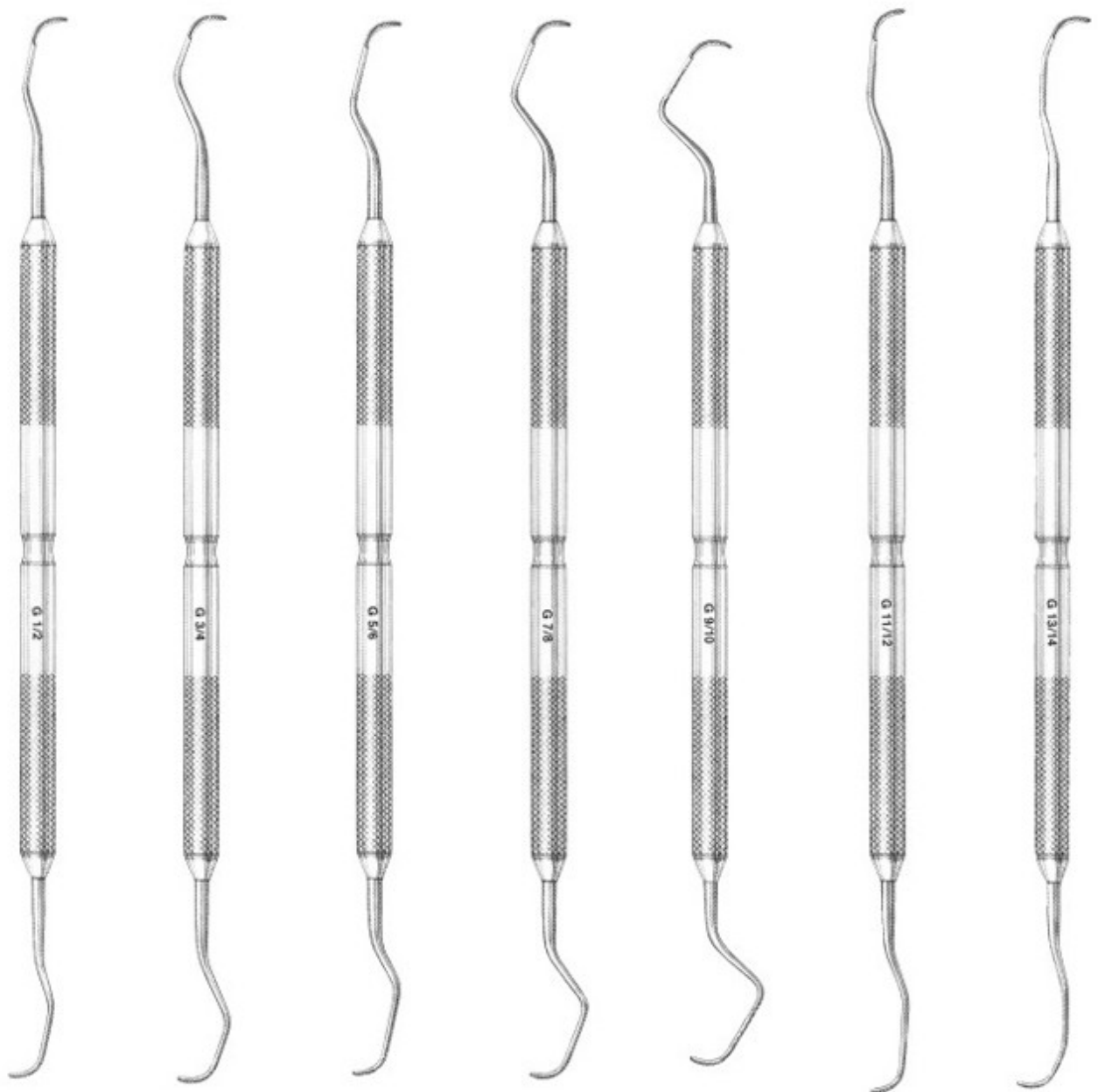

**1917**  
G1-2

**1918**  
G3-4

**1919**  
G5-6

**1920**  
G7-8

**1921**  
G9-10

**1922**  
G11-12

**1923**  
G13-14

# Curettes # 4 Handle

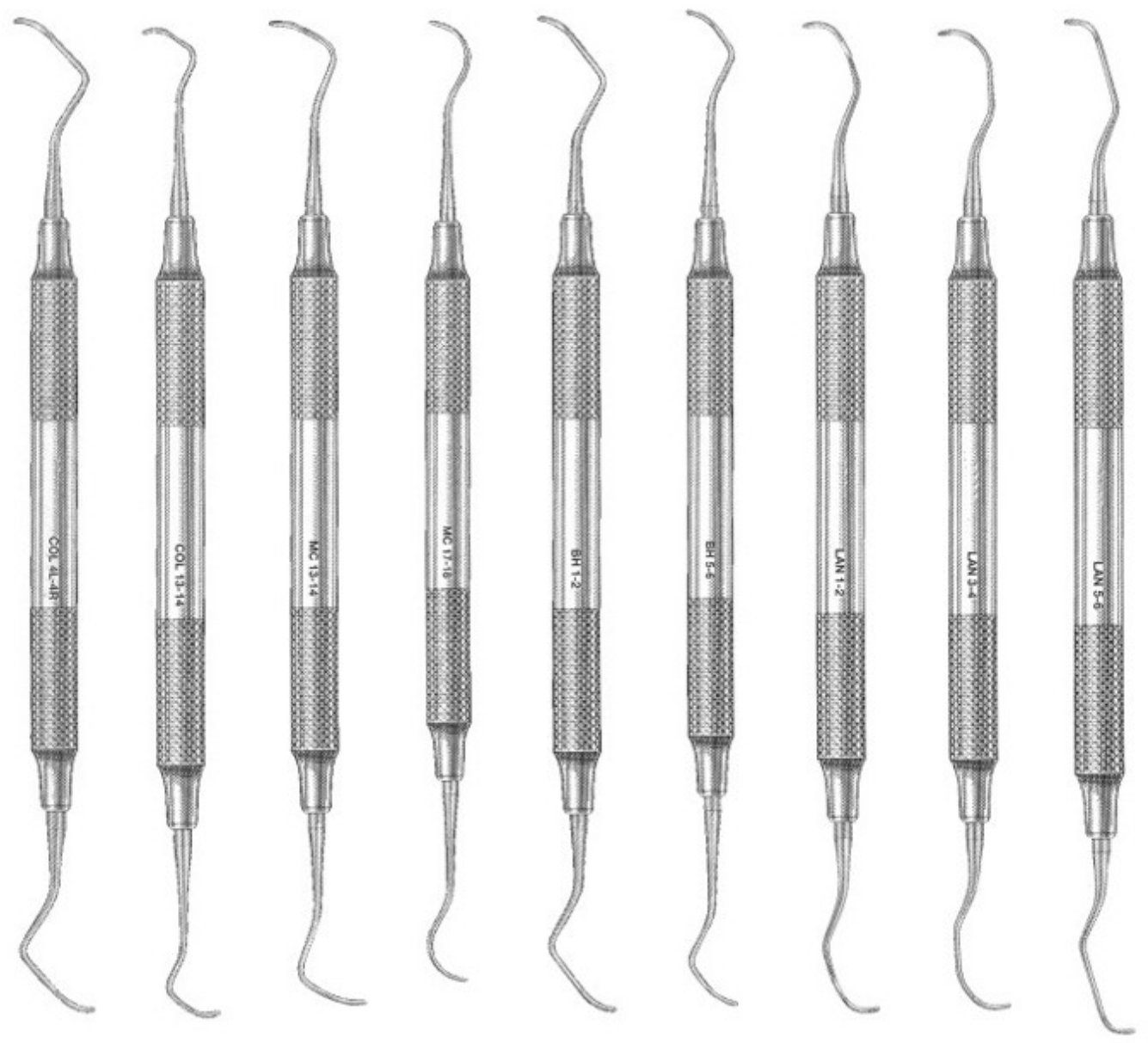

**1924**  
COLUMBIA  
4R-4L

**1925**  
COLUMBIA  
13-14

**1926**  
MCCALLS  
13-14

**1927**  
MCCALLS  
17-18

**1928**  
BARNHART  
1-2

**1929**  
BARNHART  
5-6

**1930**  
LANGER  
1-2

**1931**  
LANGER  
3-4

**1932**  
LANGER  
5-6

# Curettes

## COLUMBIA CURETTES



**1933**  
4L-4R

**1934**  
13-14

**1935**  
2L-2R

## MCCALLS CURETTES



**1936**  
13-14

**1937**  
13S-14S

**1938**  
17-18

**1939**  
17S-18S

## GOLDMAN FOX



1940  
GF1 Universal Scaler



1941  
GF2 Curette



1942  
GF3 Curette



1943  
GF4 Curette



1944  
GF5 Hoe



1945  
GF6 Hoe

## GOLDMAN FOX



**1946**  
GF 7 Knife



**1947**  
GF 8 Spear Knife



**1948**  
GF 9 Knife Scaler



**1949**  
GF 11 Spear Knife



**1950**  
GF 21 Sharp Spoon /  
Small Scaler



Ahmed Pak Impex

# Curettes, Root Planning Curettes



1951  
COLUMBIA (2L-2R)



1952  
MCCALL (13-14)



1953  
MCCALL (17S-18S)

## Root Planning Curettes



1954  
Root Plane (1-2)



1955  
Root Plane (5-6)



1957  
Root Plane (11-12)



1956  
Root Plane (7-8)



1958  
Root Plane (13-14)



1959  
Petite (1-2)



1960  
Petite (11-12)



1961  
Petite (5-6)



1962  
Petite (13-14)





# Curettes

Ahmed Pak Impex



1963  
BARNHART (1-2)



1964  
BARNHART (5-6)



1973  
COLUMBIA (4L-4R)



1965  
GRACEY (1-2)



1974  
COLUMBIA (13-14)



1966  
GRACEY (3-4)



1975  
LANGER (1-2)



1967  
GRACEY (5-6)



1976  
LANGER (3-4)



1968  
GRACEY (7-8)



1977  
LANGER (5-6)



1969  
GRACEY (9-10)



1978  
MCCALL (13-14)



1970  
GRACEY (11-12)



1979  
MCCALL (13S-14S)



1971  
GRACEY (13-14)



1980  
MCCALL (17-18)



1972  
GRACEY (2L-2R)



1981  
MCCALL (17S-18S)



1982  
RULE (3-4)



# Dental Products

Silicon Handles-Reusable

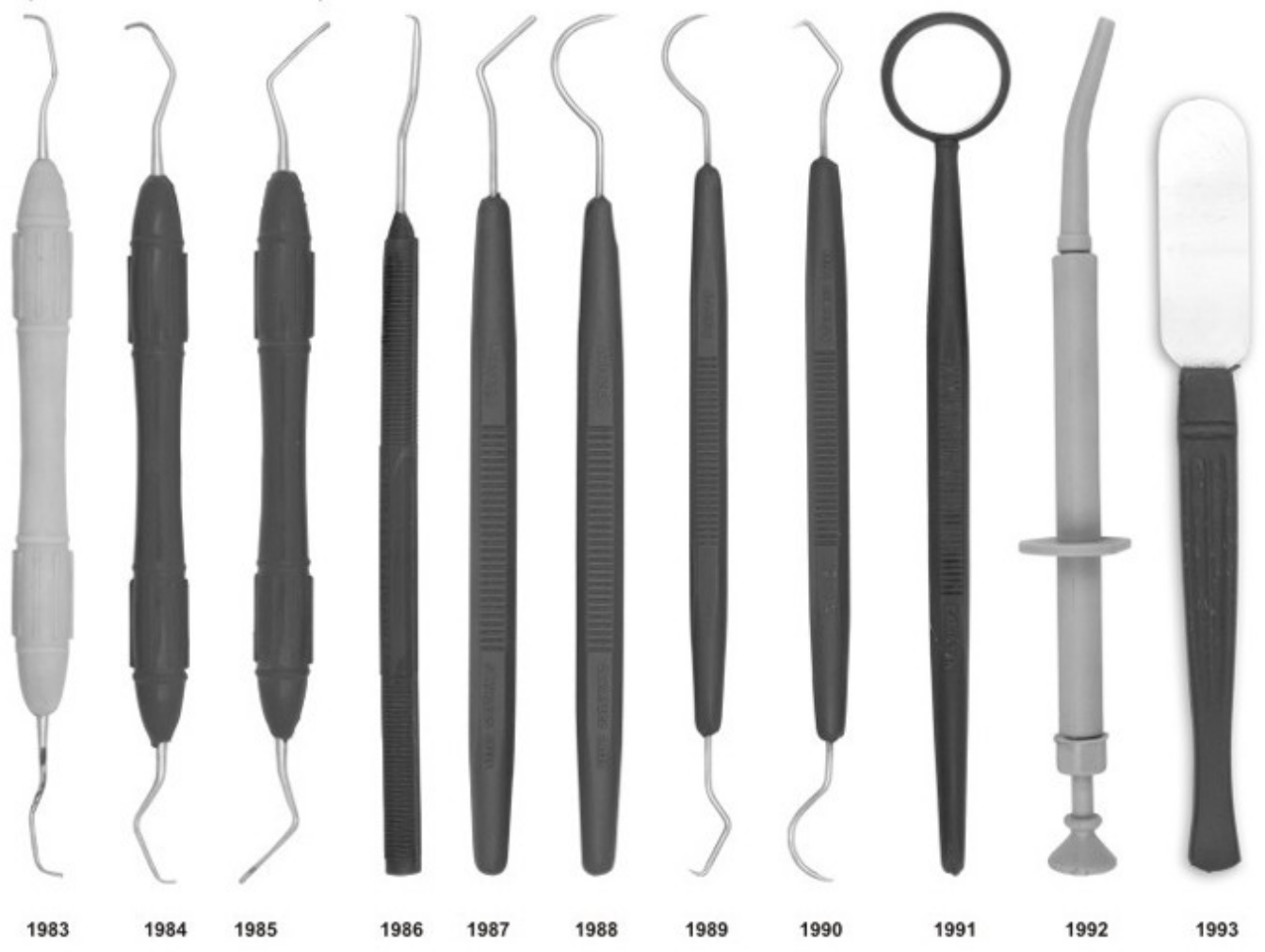

1983 1984 1985 1986 1987 1988 1989 1990 1991 1992 1993



1994 1995 1996 1997

# Wax, Porcelain & Cement Instruments

## Comfort Grip Vinyl - Covered Insulating Handles



# Wax, Porcelain & Cement Instruments

## P.K. THOMAS

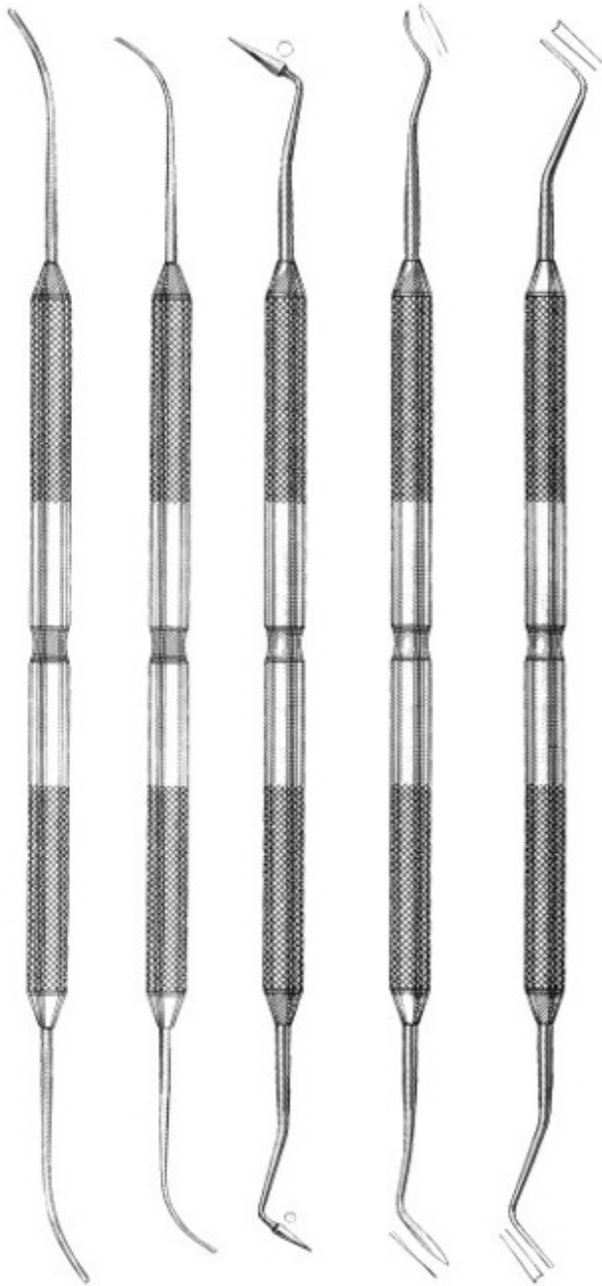

2009 PKT 1      2010 PKT 2      2011 PKT 3      2012 PKT 4      2013 PKT 5

Set of 5 instruments

## WAX CARVERS

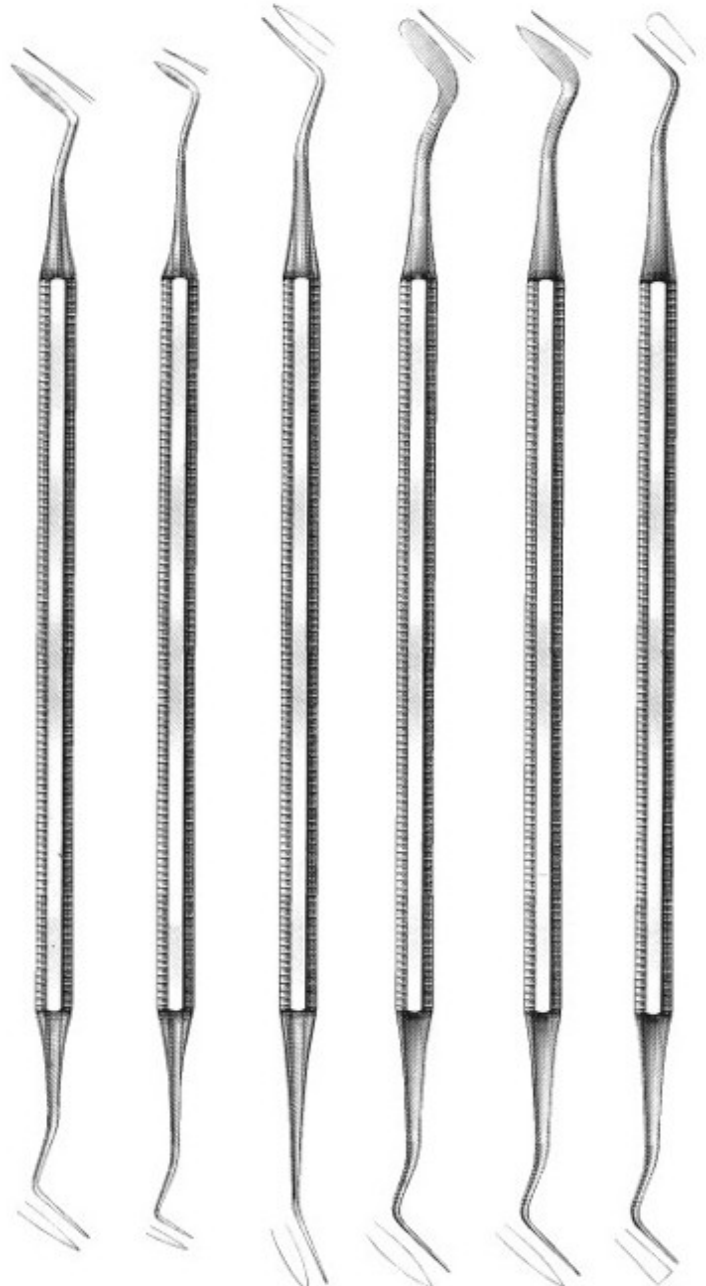

2014 Hollenback 3      2015 Hollenback 3S      2016 WARD 1      2017 WARD 2      2018 WALL 1      2019 WALL 3

# Wax & Modeling Carvers, Cement Spatulas

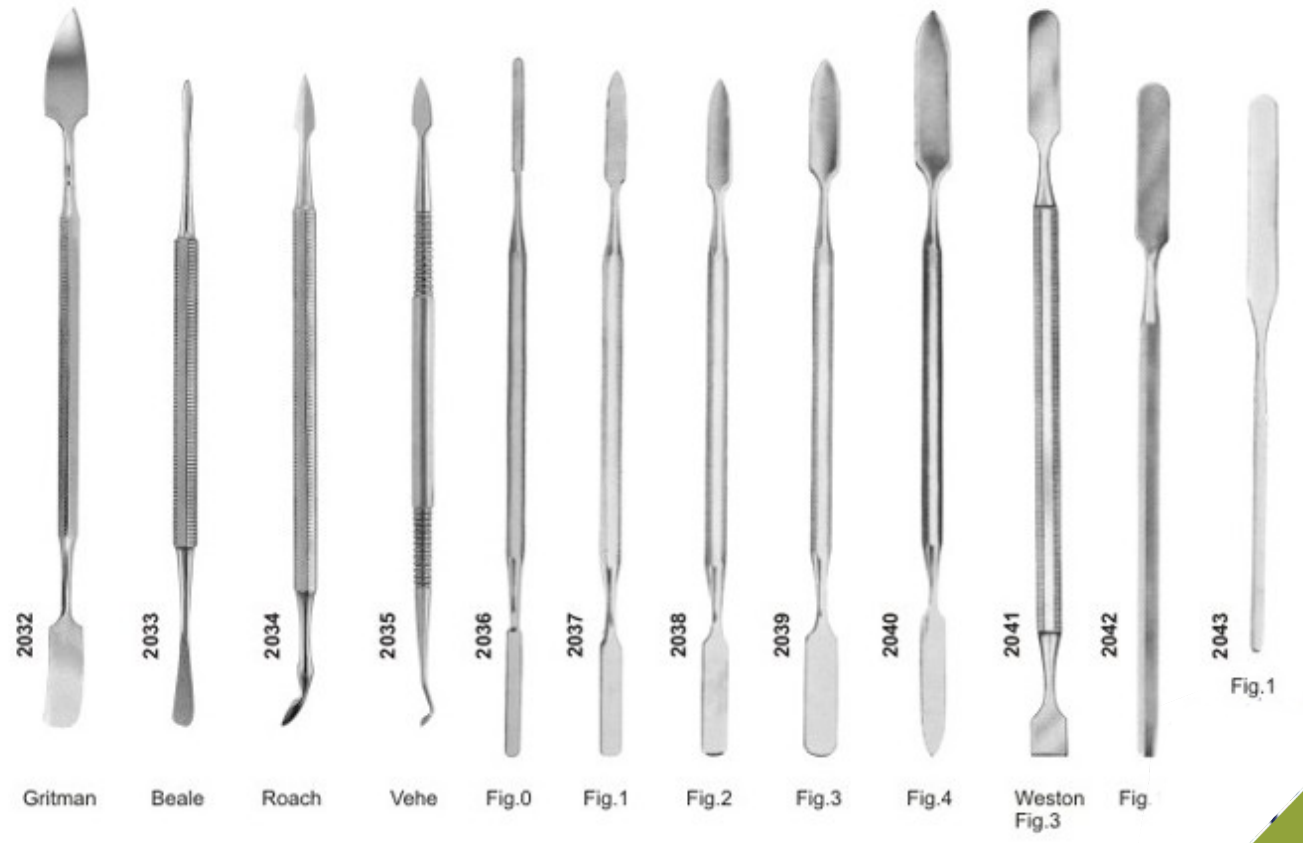
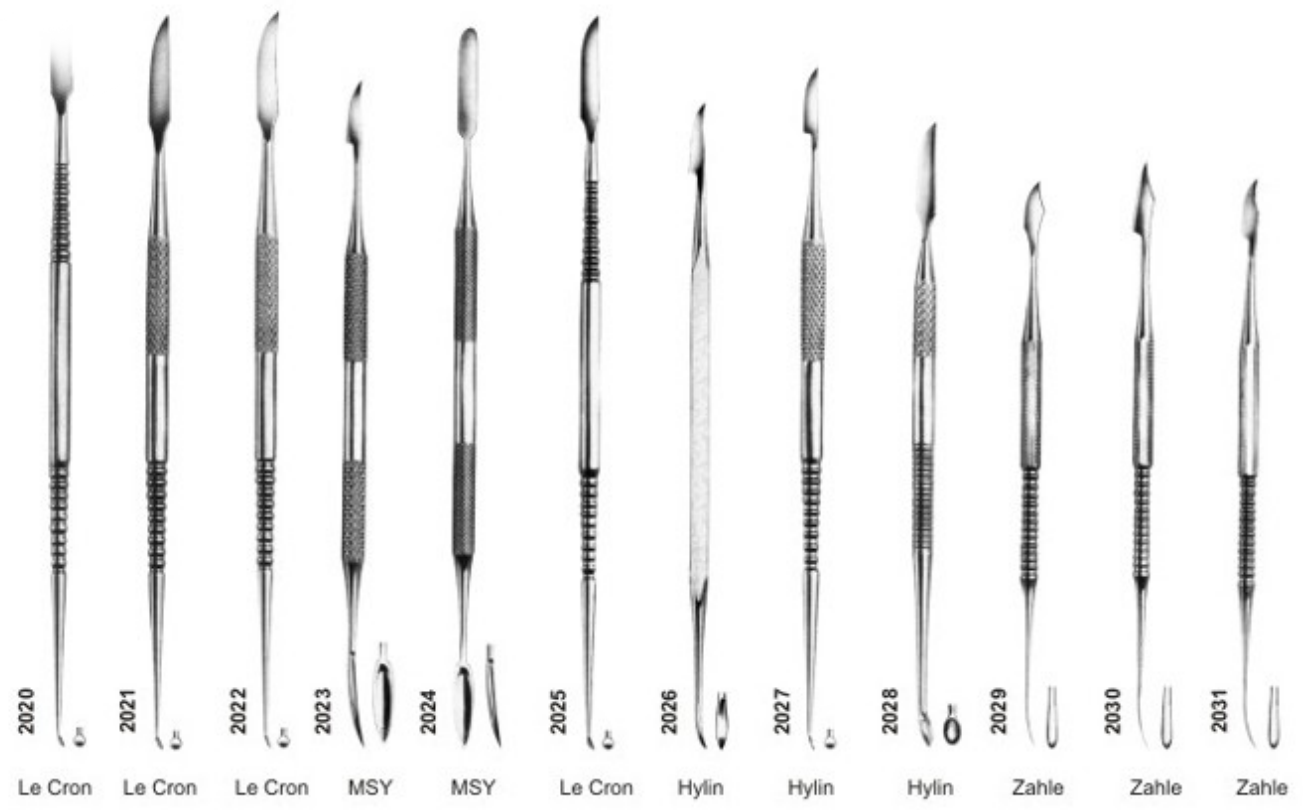



Ahmed Pak Impex

# Wax, Porcelain & Cement Instruments

## WAX & PORCELAINE CARVERS



2044  
LECRON  
Inlay

2045  
REEVES

2046  
VEHE  
Wax

2047  
ROACH  
Wax

## WAX SPATULAS

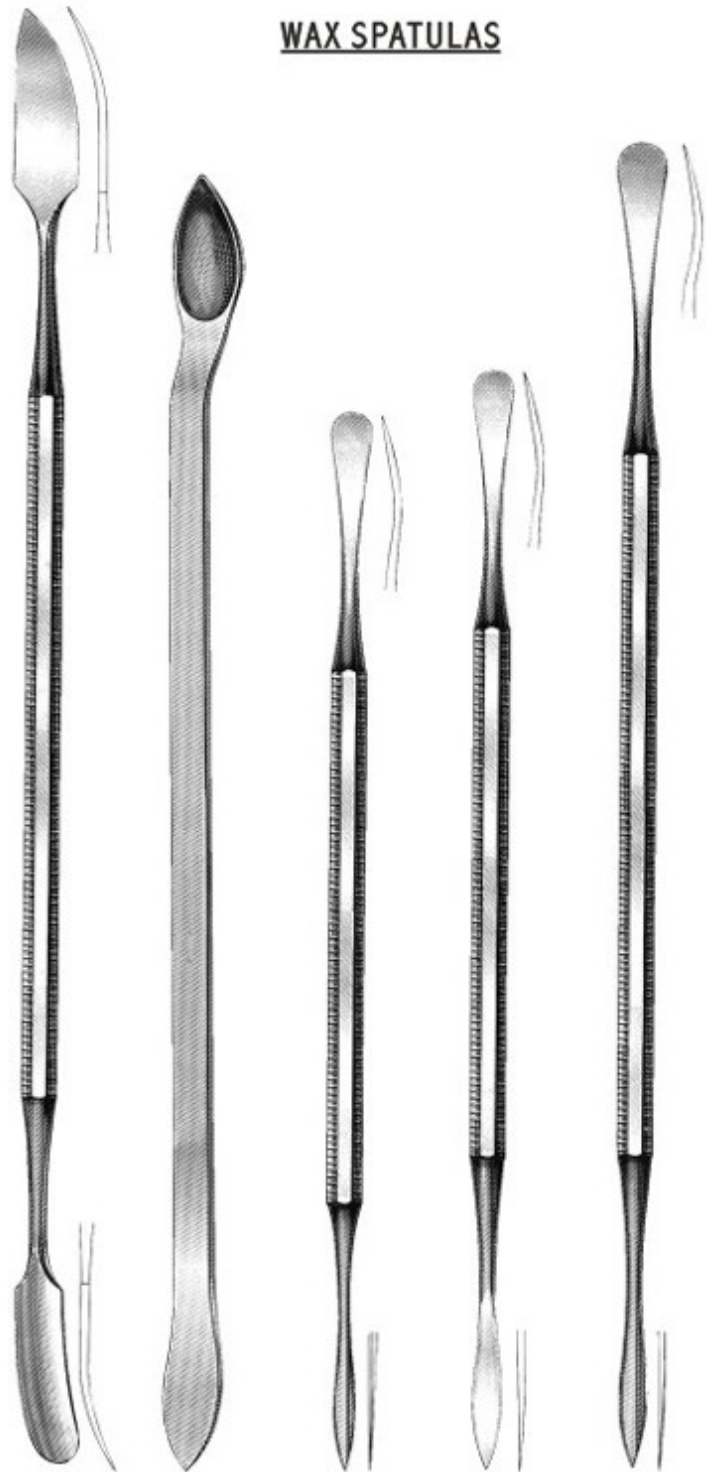

2048  
W-31

2049  
W-5

2050  
W-7

2051  
W-7A

2052



Ahmed Pak Impex

# Cement Spatulas



2053  
AGATHE



2054  
C-7



2055  
C-5



2056  
C-313



2057  
C-24A Rigid



2058  
C-24 Flexible



2059  
C-24 Flexible



2060  
24



2061  
A6



2063  
7 Wax



2062  
26



2065  
31



2064  
All Metal Spatulas with High Polish  
Stainless Steel Blade

# Spatulas

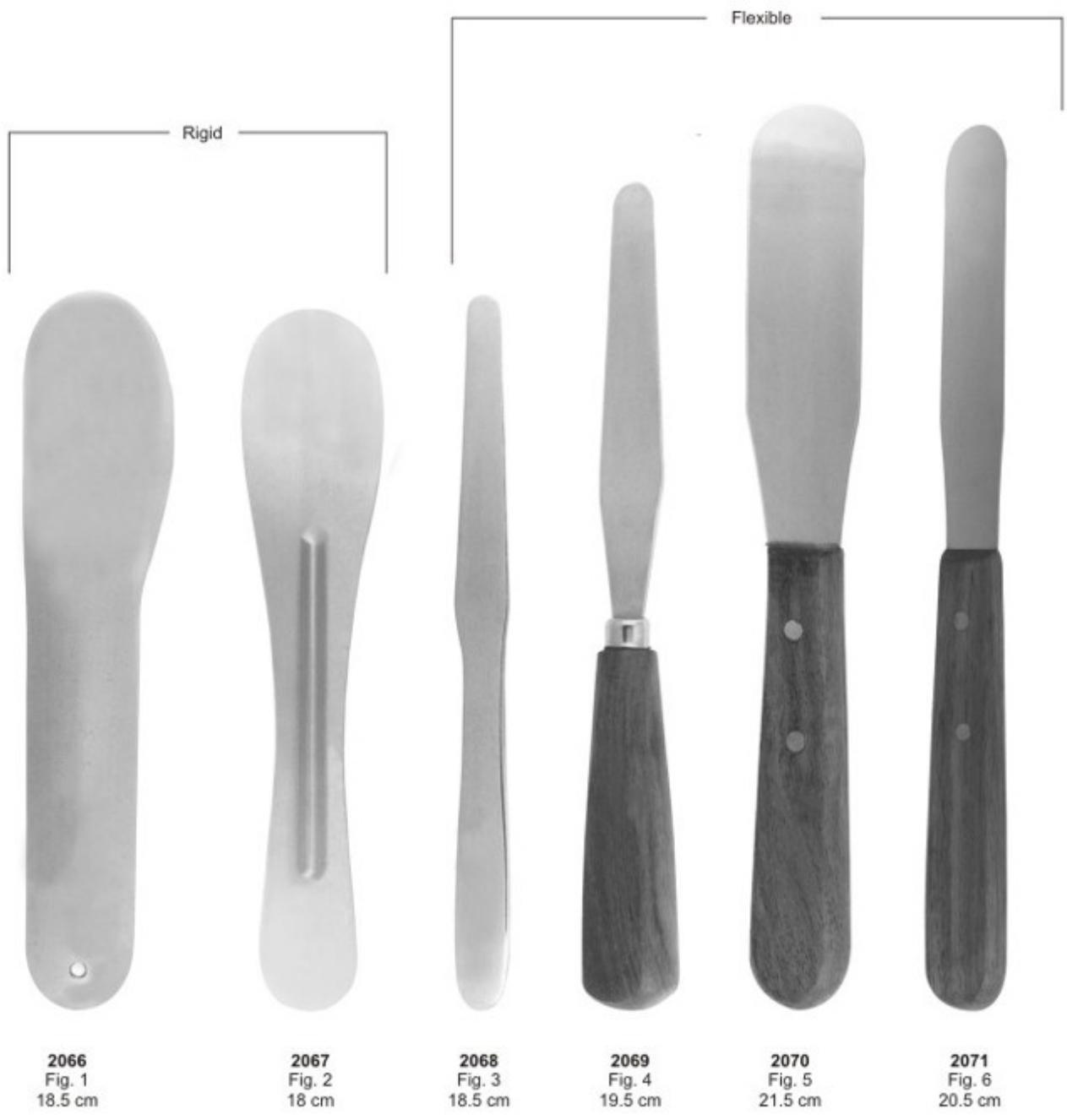



# Spatulas





# Files, Hoes & Knives

## FILES

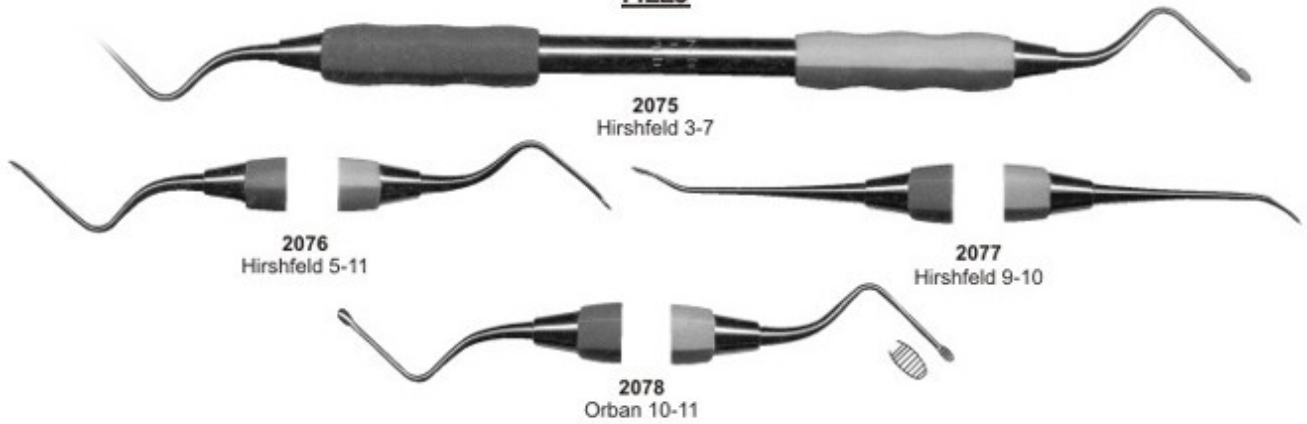

## HOES

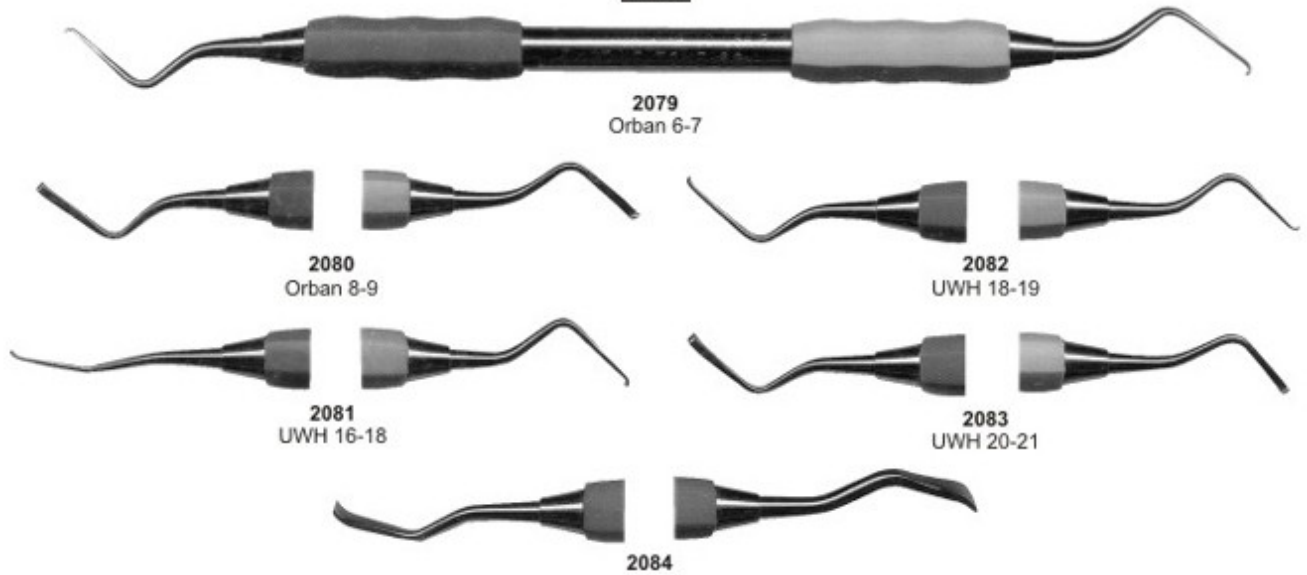

## KNIVES

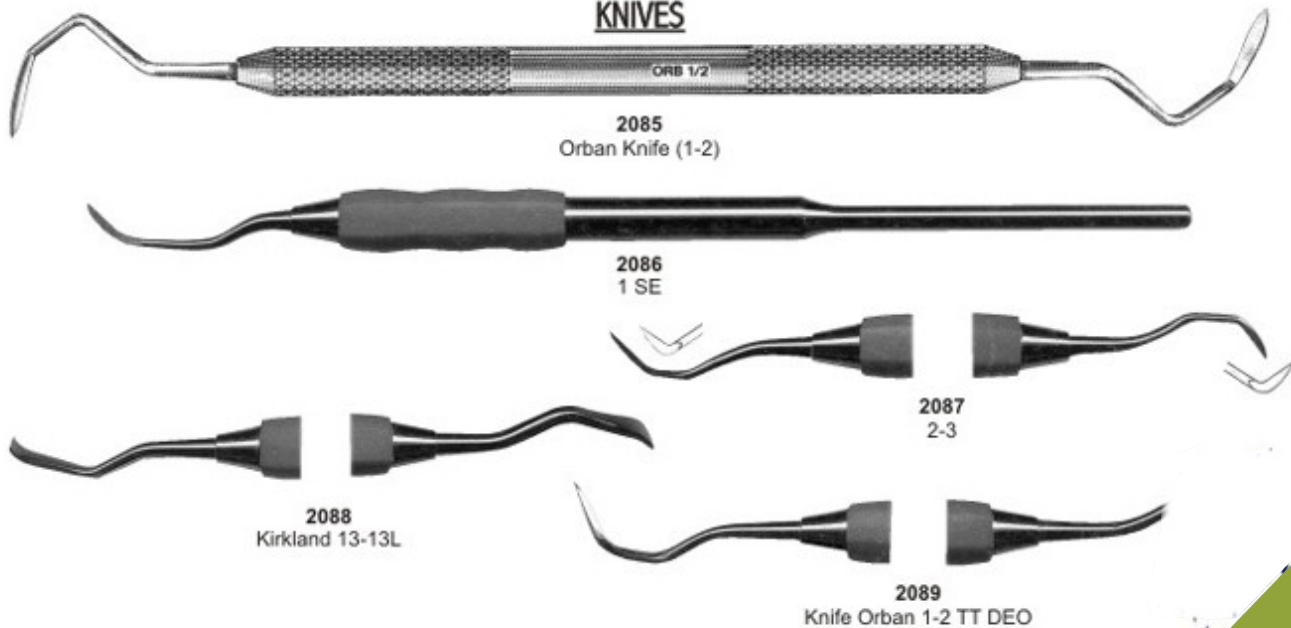

# Wax Knives



**2090**  
Fahnenstock  
Fig. 1  
12,5cm

**2091**  
Fahnenstock  
Fig. 2  
17cm

**2092**  
Lessmann  
Fig. 1  
12,5cm

**2093**  
Lessmann  
Fig. 2  
17cm

**2094**  
Con scodellino  
Fig. 1  
12,5cm

**2095**  
Con scodellino  
Fig. 2  
17cm

**2096**  
Ermert

**2097**  
Ermert

# Wax Knives & Plaster Knives



**2098**  
18 cm  
7 1/8"



**2099**  
18 cm  
7 1/8"



**2100**  
17 cm  
6 3/4"  
Gritman



**2101**  
17 cm  
6 3/4"  
Medicon



**2102**  
Fig. 1  
17 cm



**2103**  
22 cm  
8 3/4"



**2104**  
22 cm  
8 3/4"



**2105**  
Gritman  
Fig. 2  
17 cm



**2106**  
Fig. 3  
16 cm



**2107**  
Fig. 1  
16 cm

# Crane-Kaplan, Ochsenbein

## CRANE-KAPLAN



2108  
Ck1  
Pocket Marker

2109  
Ck2  
Pocket Marker

2110  
Knife

2111  
Dissector

2112  
Scaler

## OCHSENBEIN



2113  
Ochsenbein  
Fig. 1

2114  
Ochsenbein  
Fig. 2

2115  
Ochsenbein  
Fig. 4



# Bone Currettes

Ahmed Pak Impex

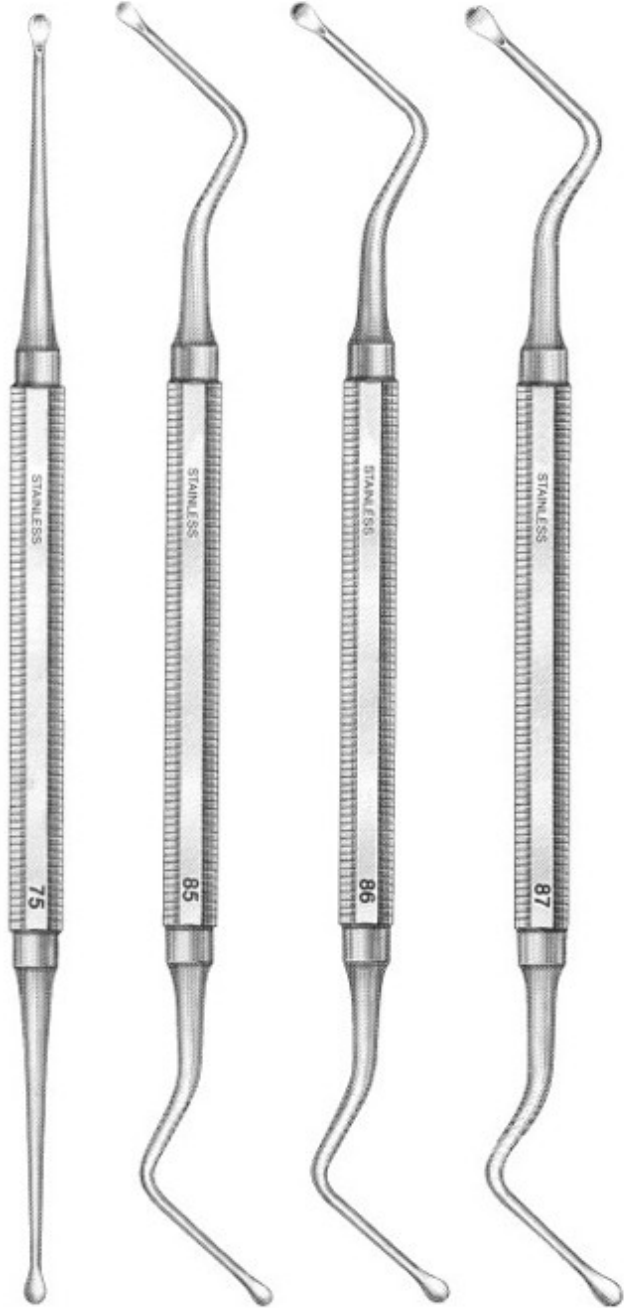

2116  
No. 75

2117  
No. 85

2118  
No. 86

2119  
No. 87



2120  
No. 2/4



2121  
No. 1



2122  
No. 2



2123  
No. 4



2124  
No. 5L



2125  
No. 6R



# Bone Files

Ahmed Pak Impex

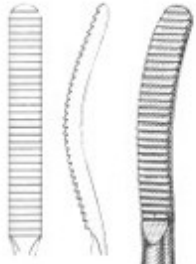

**2126**  
No. 10

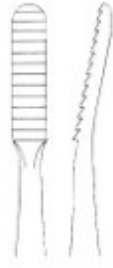

**2127**  
No. 33



**2128**  
MILLER  
No. 33



**2129**  
MILLER  
No. 64

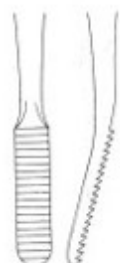
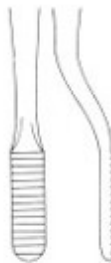

# Bone Files

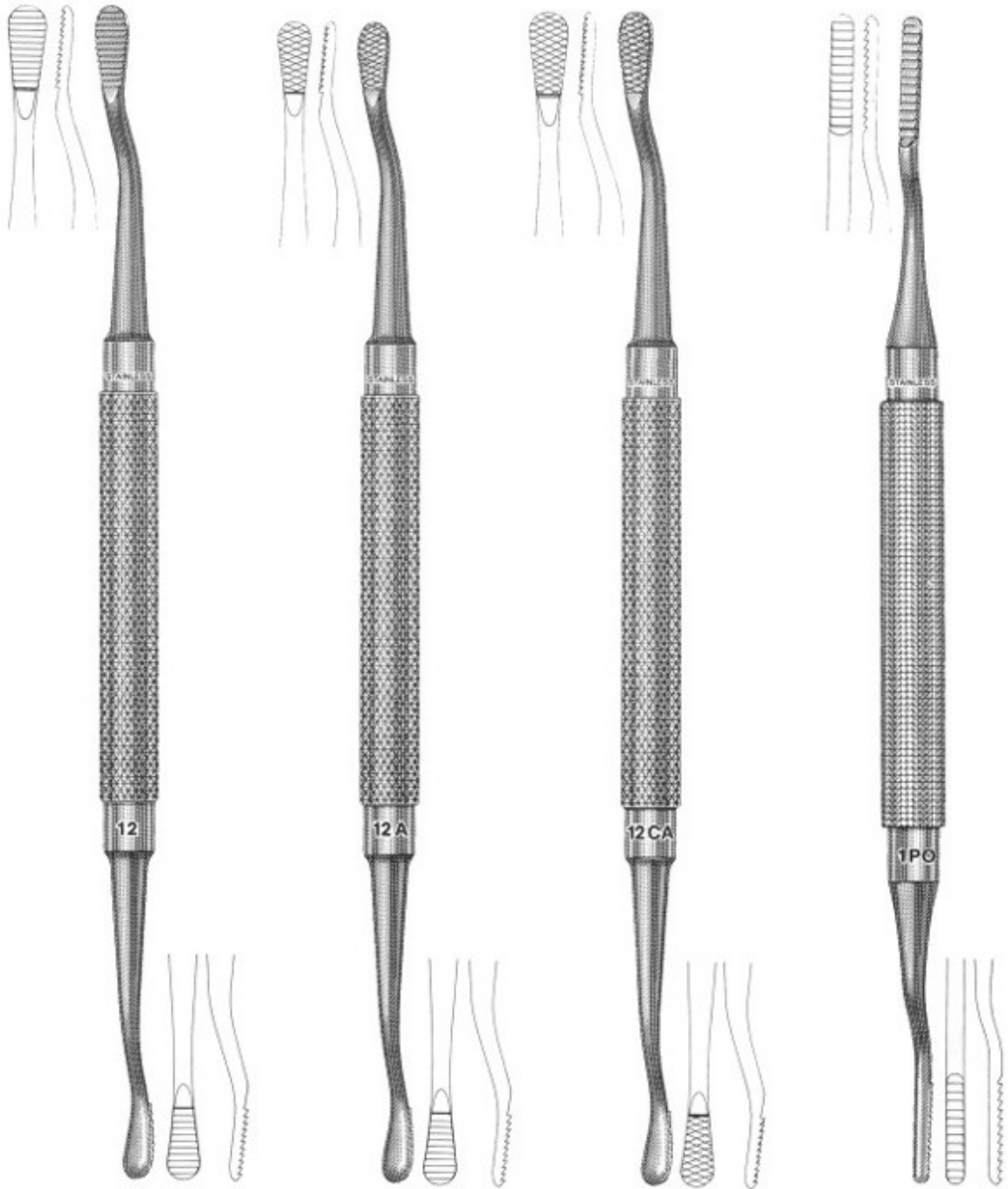

**2130**  
HOWARD  
No. 12

**2131**  
HOWARD  
No. 12A

**2132**  
HOWARD  
No. 12CA

**2133**  
POLOKOFF  
No. 1



# Bone Chisels

## GARDNER



2134 GARDNER No. 1  
 2135 GARDNER No. 2  
 2136 GARDNER No. 5  
 2137 GARDNER No. 5R

## WAKEFIELD



2138 WAKEFIELD No. 1W  
 2139 WAKEFIELD No. 2W

# Bone Chisels, Bone Mallets

## Bone Chisels and Gouges

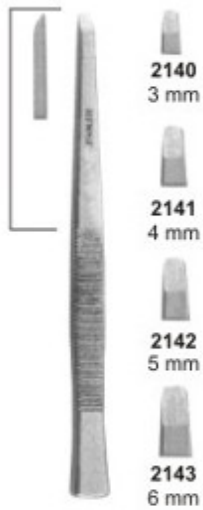

PARTSCH  
13,5 cm

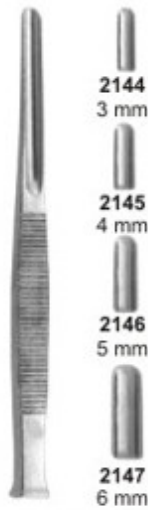

PARTSCH  
13,5 cm

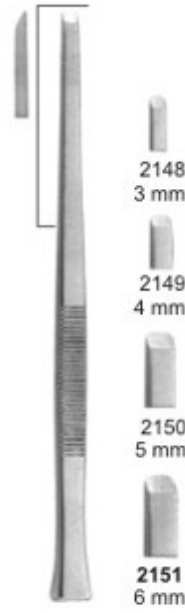

PARTSCH  
17 cm

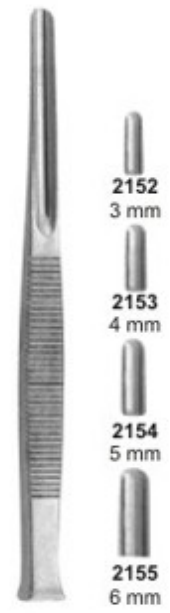

PARTSCH  
17 cm

### Martelli chirurgici Mallet

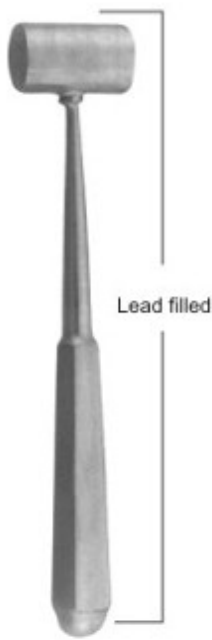

2156  
PARTSCH  
19 cm

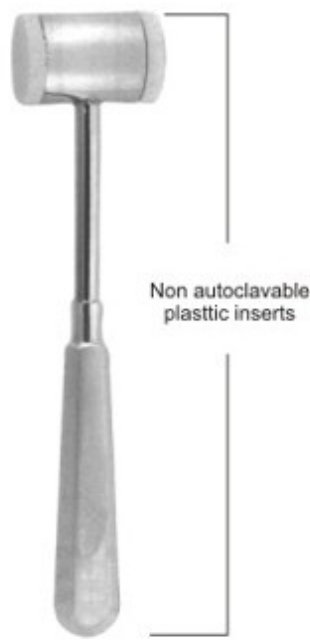

2157  
MEAD  
19,5 cm

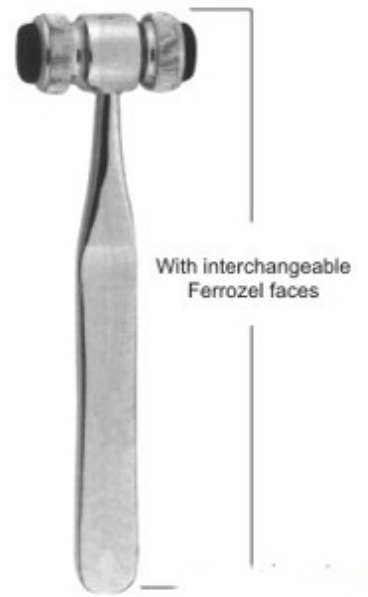

2158  
MEAD  
17 cm

# Crown Removers

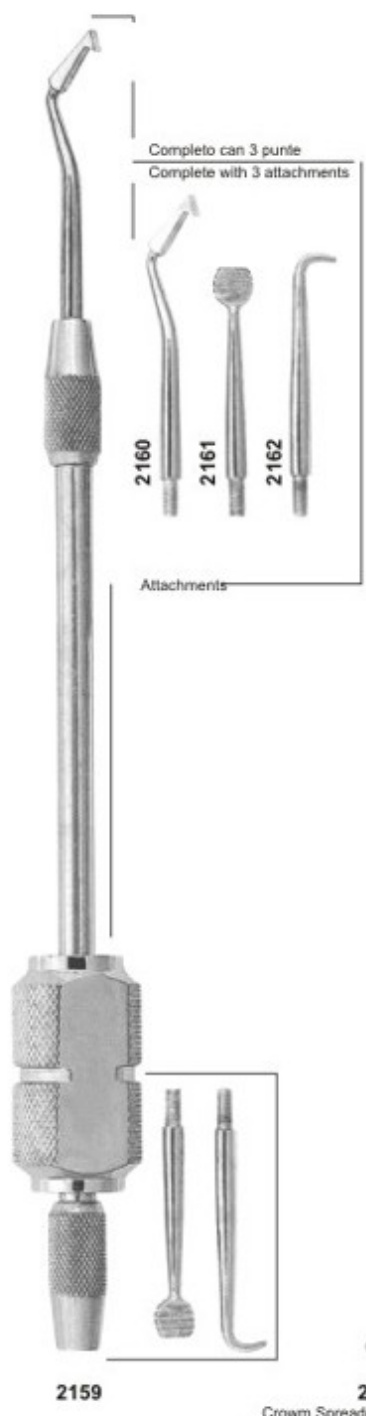

**2163**  
Crown Spreader, Crown Remove.  
Special instrument for crown spreading  
after separating, simple and safe  
operation.

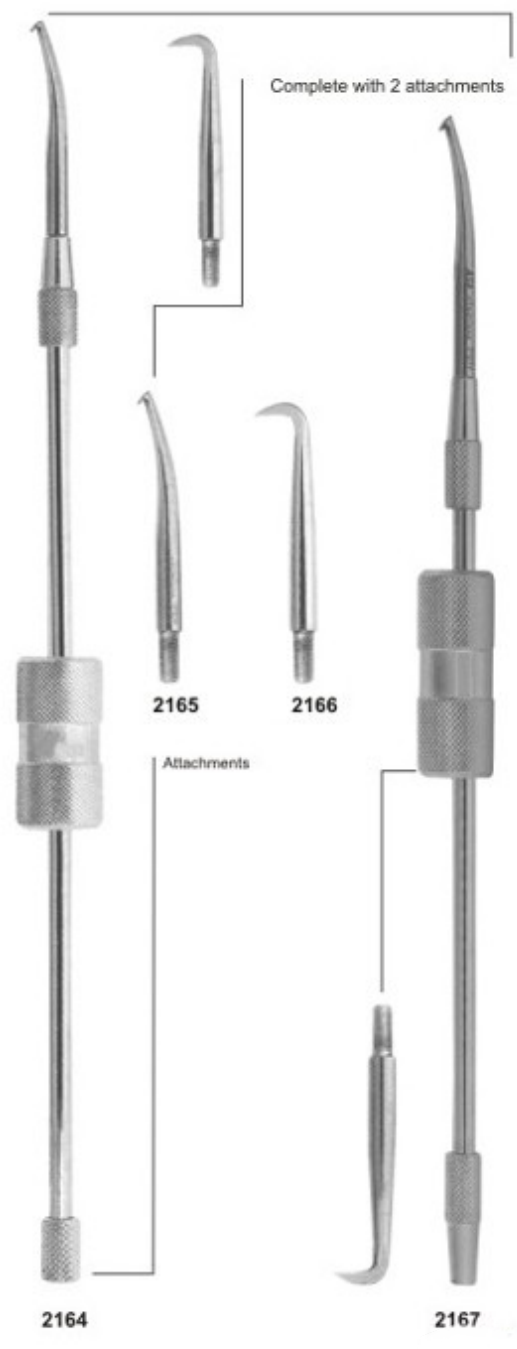



# Crown Instruments

Ahmed Pak Impex

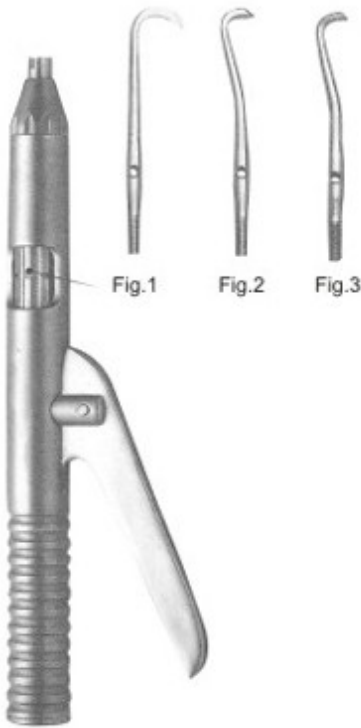

**2168**  
Crown Remover



**2169**  
Crown Remover



**2170**  
single loop  
with adapter



KEY/9



ADAPTER/8



**2173**  
Crown & Bridge Holding Forceps  
With Support Ring



**2174**  
WYNMAN  
Crown Gripper, CARB-N-SERT

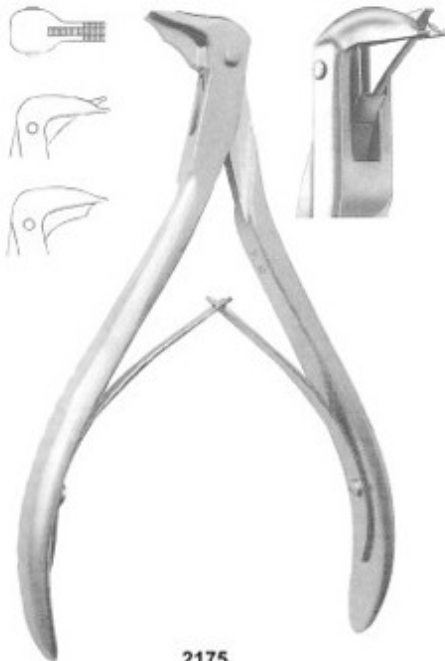

**2175**  
Crown opener



**2176**  
Universal  
Hollow Handle



**2177**  
Fig.2



**2178**  
Fig.3



**2179**  
Fig.4



Fig.1

# Crown Instruments

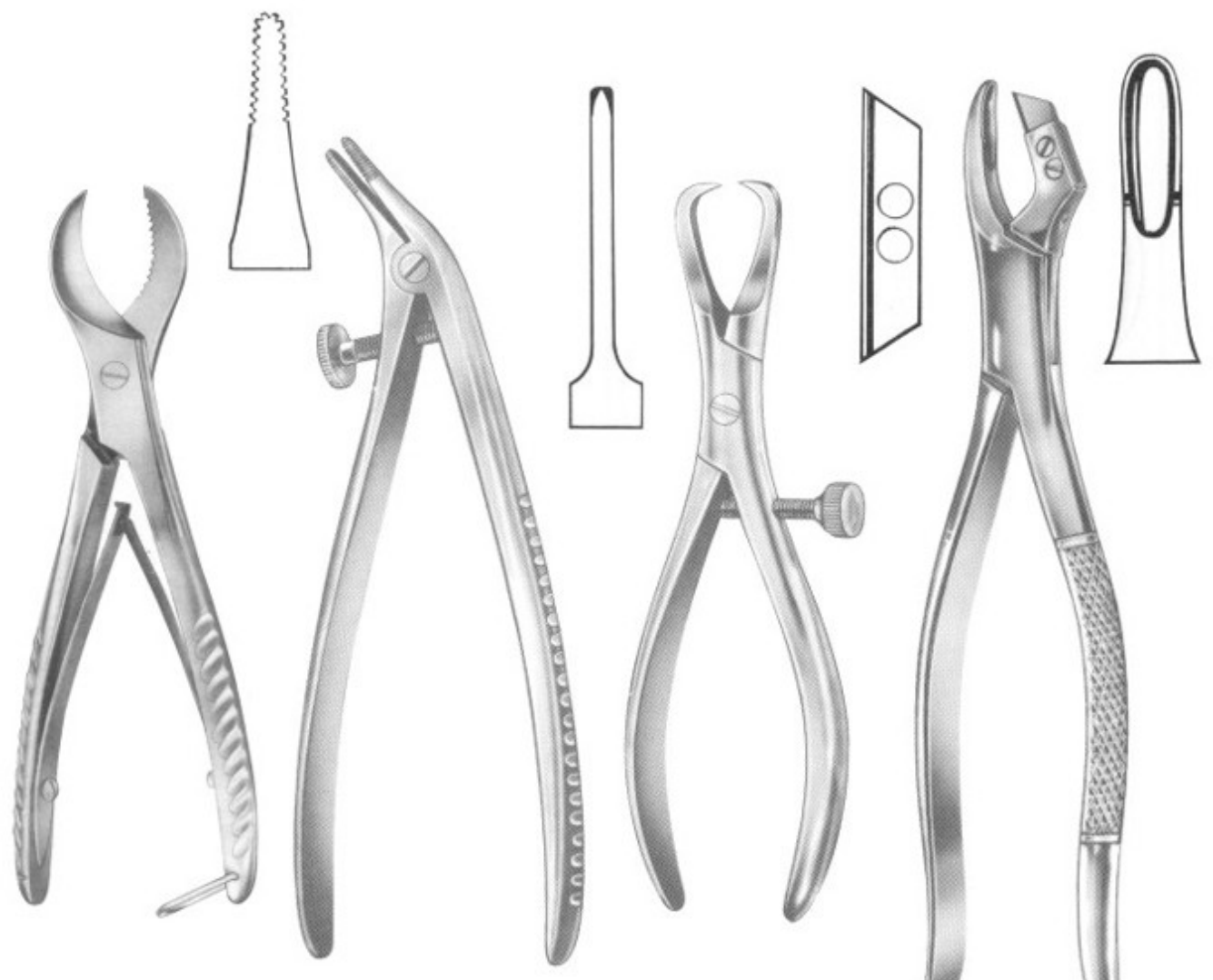

**2180**  
Plaster Shear  
210 mm

**2181**  
BOHM  
16 cm

**2182**  
Crown Removing Plier  
14 cm

**2183**  
MONTFORT  
18 CM





# Implants Instruments

Ahmed Pak Impex



**2186**  
Fig. 1B  
165 mm



Ø 2 mm  
1B



Ø 3 mm  
2B

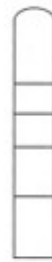

Ø 3.3 mm  
3B

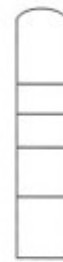

Ø 4 mm  
4B

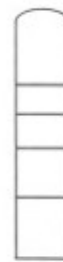

Ø 5 mm  
5B

6 mm  
8 mm  
11 mm  
15 mm



Ø 2 mm  
1BCC



Ø 3 mm  
2BCC

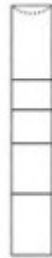

Ø 3.3 mm  
3BCC



Ø 4 mm  
4BCC

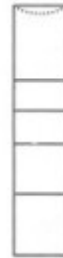

Ø 5 mm  
5BCC

6 mm  
8 mm  
11 mm  
15 mm



**2187**  
Fig. 1  
155 mm



Ø 2 mm  
1RRT



Ø 3 mm  
2RRT

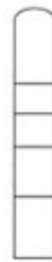

Ø 3.3 mm  
3RRT

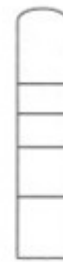

Ø 4 mm  
4RRT

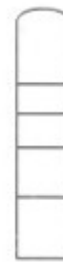

Ø 5 mm  
5RRT

6 mm  
8 mm  
11 mm  
15 mm



Ø 2 mm  
1RRC

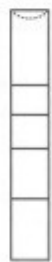

Ø 3 mm  
2RRC

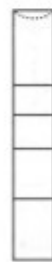

Ø 3.3 mm  
3RRC

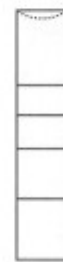

Ø 4 mm  
4RRC



Ø 5 mm  
5RRC

6 mm  
8 mm  
11 mm  
15 mm



Ahmed Pak Impex

# Implants Instruments

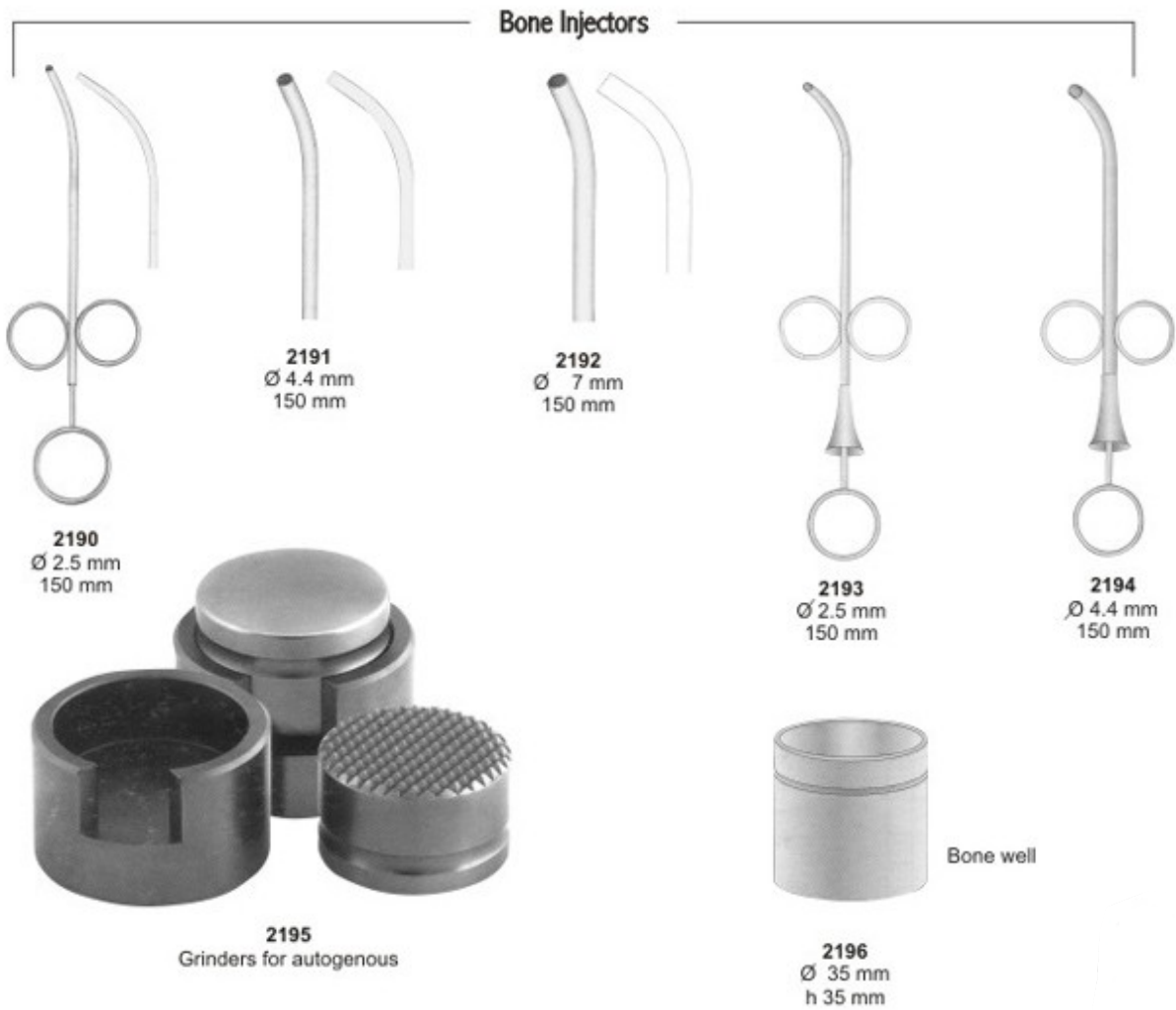
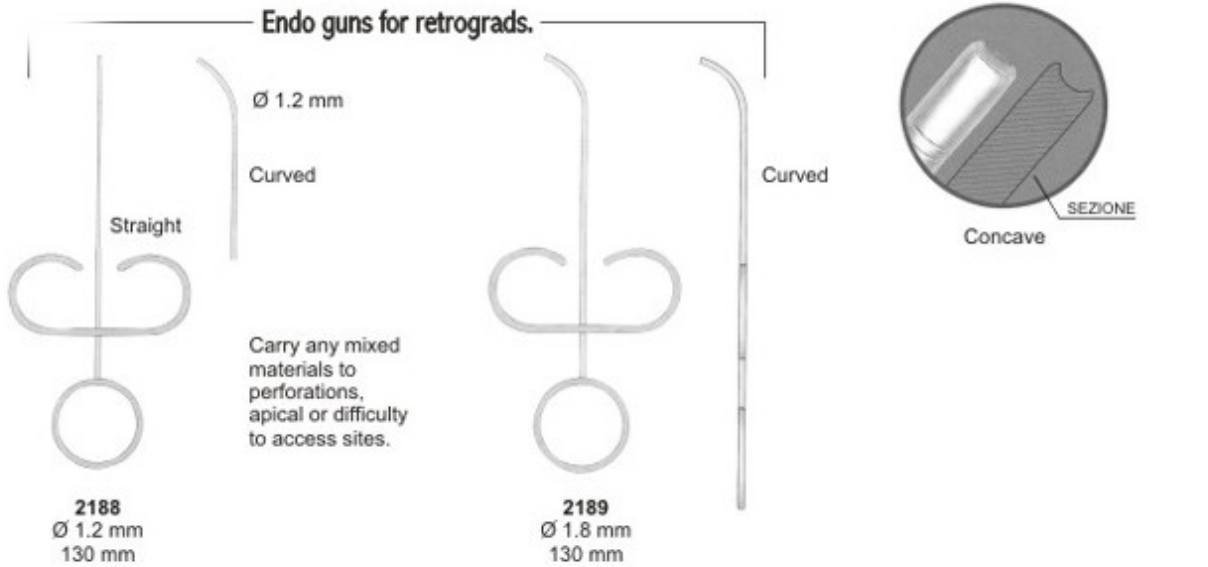





**2197**  
Fig. 1  
170 mm

**2198**  
Fig. 2  
175 mm

**2199**  
Fig. 3  
170 mm

**2200**  
LUCAS  
Fig. 88  
170 mm

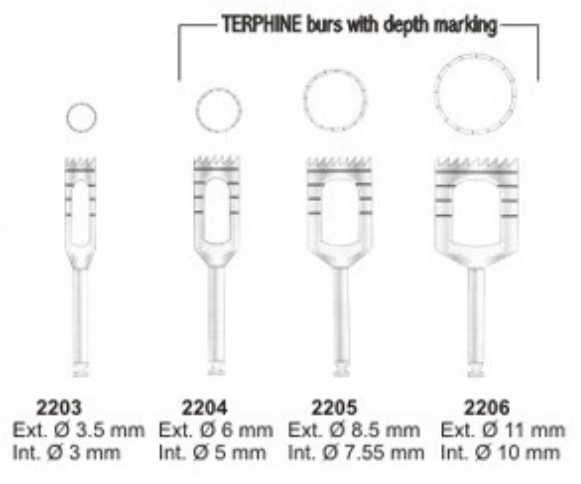

## Sinus lift instruments



**2207**  
Fig.1

**2208**  
Fig.2

**2209**  
Fig.3

**2210**  
Fig.4

**2211**  
Fig.5

**2212**  
Fig.6

**2213**  
Fig.7

**2214**  
Fig.8



# Measuring Instruments

Ahmed Pak Impex



**2216**  
BOLEY Gauge



**2217**  
ZURICHER  
130 mm



**2218**  
VERNIER  
12 cm



**2219**  
VERNIER



**2220**  
Height Gauge  
Wick Type

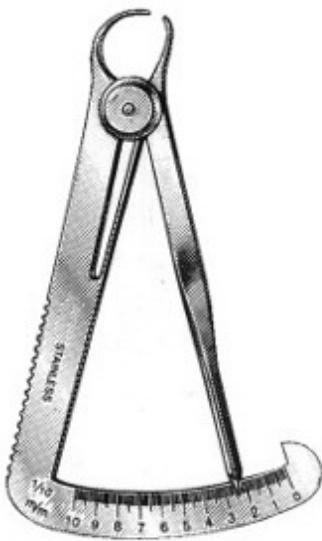

**2221**  
LWANSON  
Crown Gauge



**2222**  
CASTROVIEJO'S  
Sclerer Marker



**2223**  
Spring Bow Divider  
6" Radius



**2224**  
ALBEE



# Scalers

Ahmed Pak Impex



1522  
JAQUETTE (33-U15)



1523  
S204



1524  
S204S



1525  
S204SD



1526  
Goldman 6-7



1527  
Goldman Fox 21



1528  
H5-U15



1529  
Jaquette 34-35



1530  
Thompson Jr.



1531  
UT107-108



1532  
UP128



1533  
Jack-Nebraska



1534  
Jaquette 1-U15

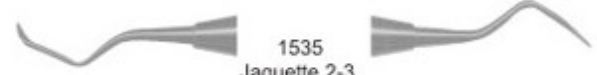

1535  
Jaquette 2-3



1536  
Jaquette 2S-3S



1537  
Jaquette 30-U15



1538  
Jaquette 30-33



1539  
Jaquette 31-32

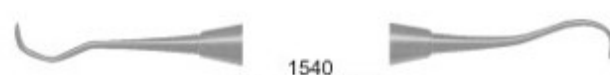

1540  
Jaquette 33-H5



1541  
U 6-7



1542  
128L



# Explorers

Ahmed Pak Impex

## Explorers Double Ended - Octagonal

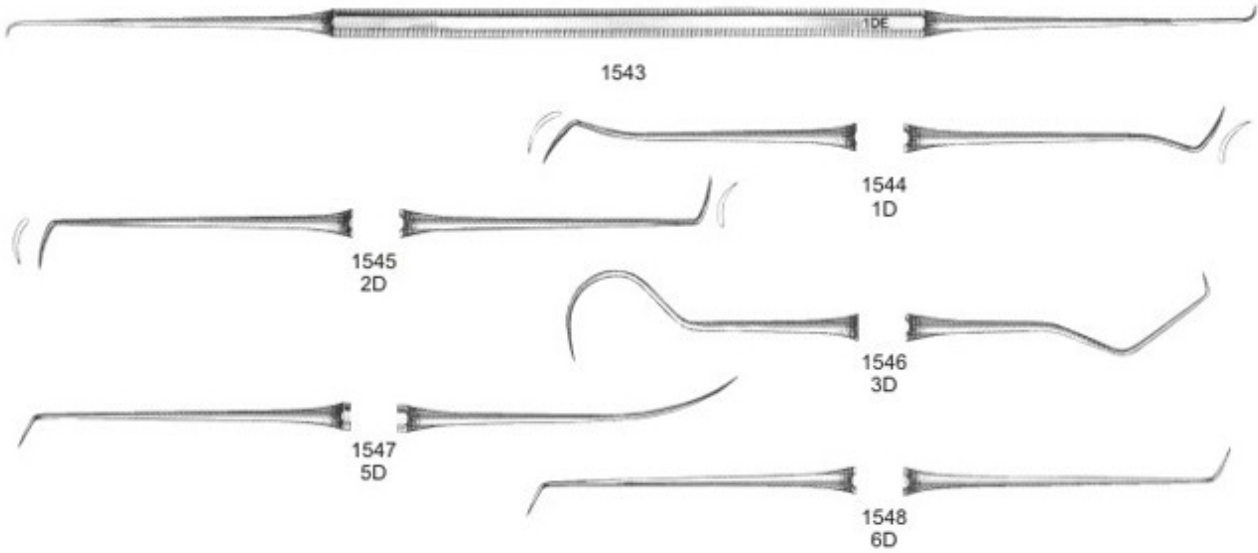

## Explorers Double Ended - Standard

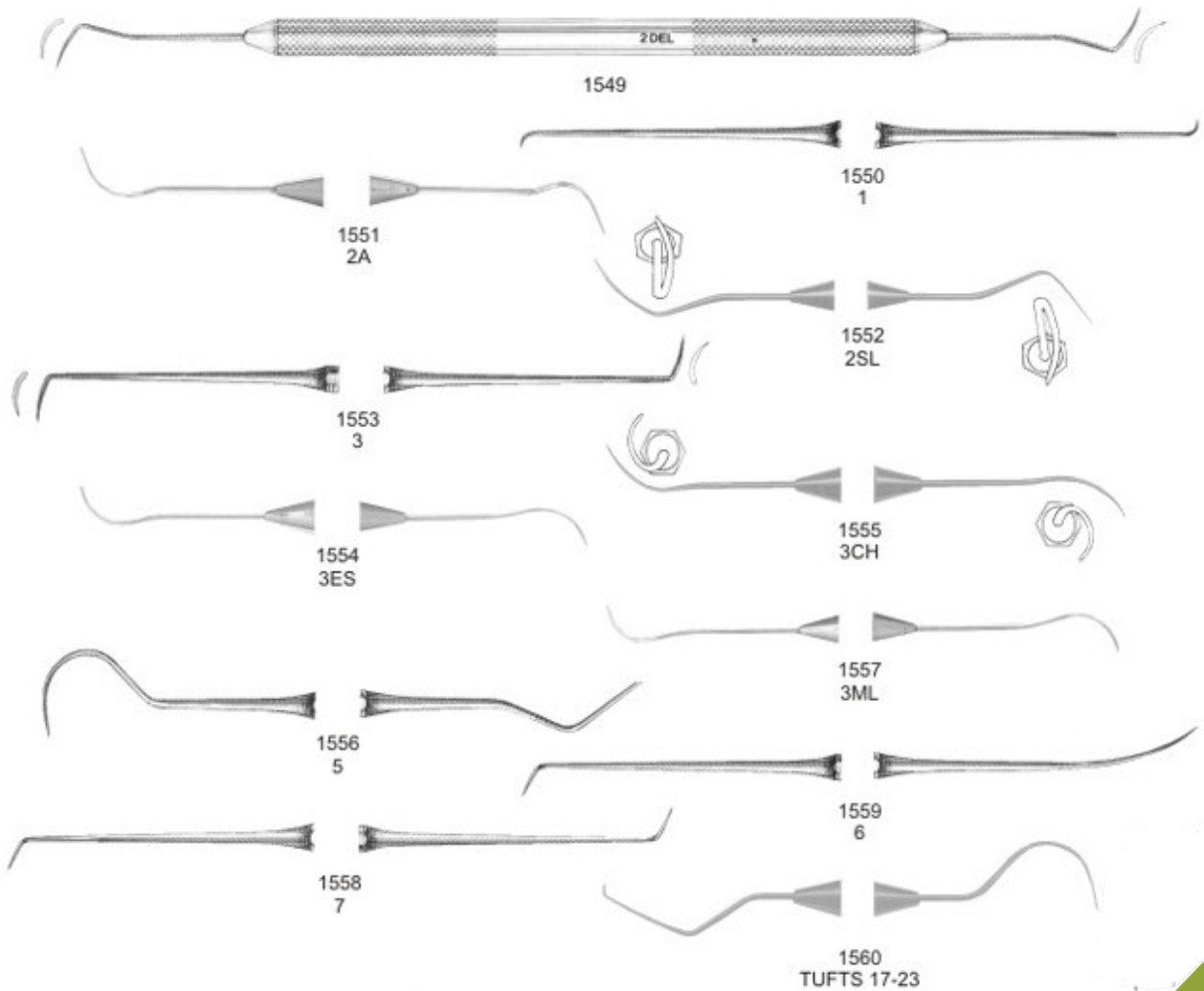



# Explorers

Ahmed Pak Impex

## Explorers Double Ended Tactile Tone



1561  
2A



1562  
2



1568  
1



1563  
2SL



1569  
3



1564  
3CH



1570  
3ES



1565  
3ML



1571  
5



1566  
6



1572  
7



1567  
16



1573  
TUFTS 17/23

# Explorers & Probes

## Explorers Single Ended - Octagonal

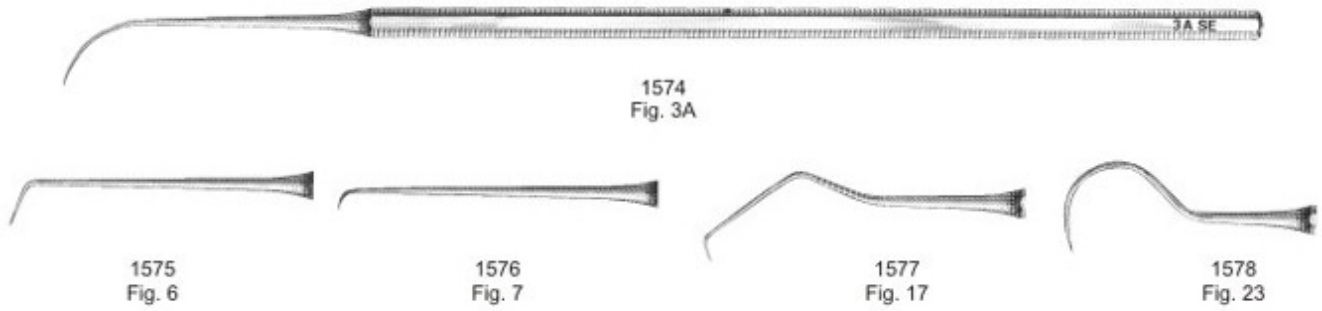

## Explorers Single Ended - Standard

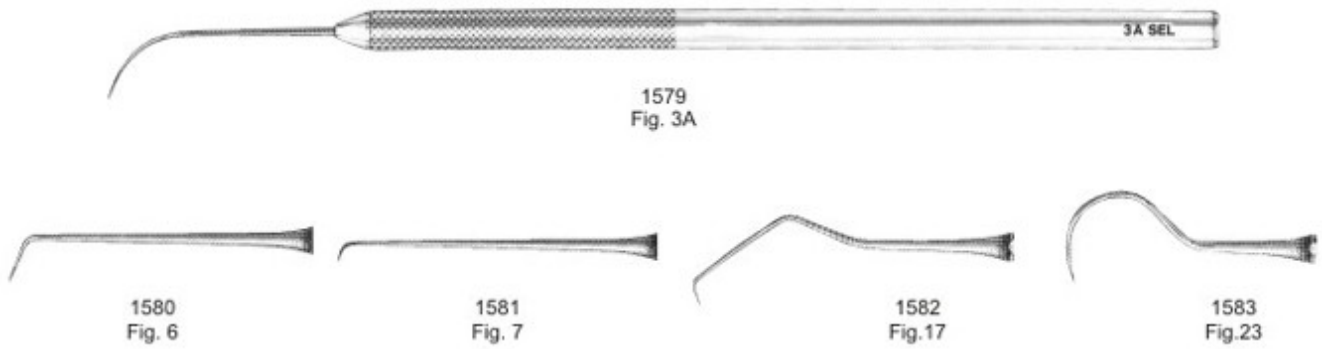

## Probe / Explorer - Octagonal



## Double Ended Probe - Octagonal

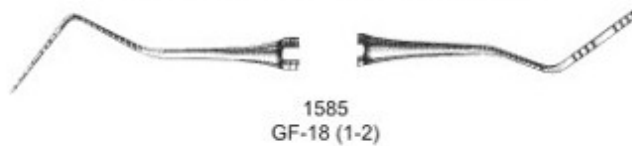



# Probes

Ahmed Pak Impex

## Probes Double Ended - Standard

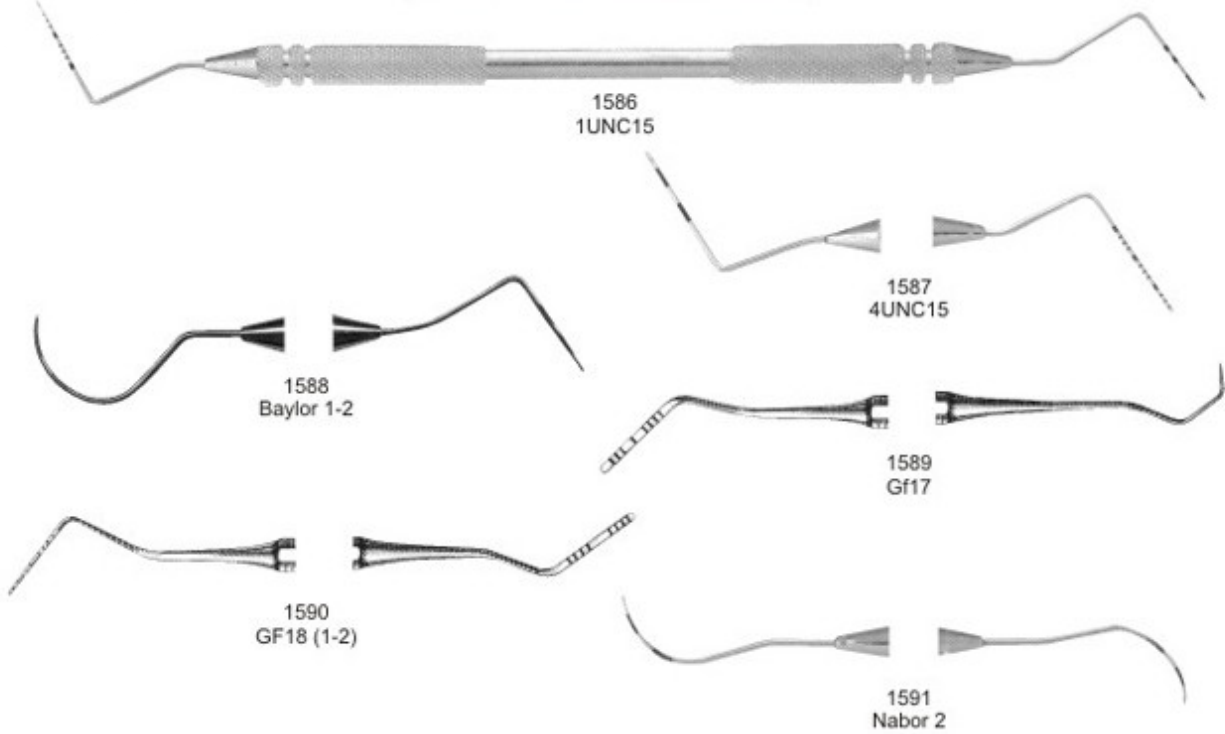

## Probes Double Ended - Tactile Tone

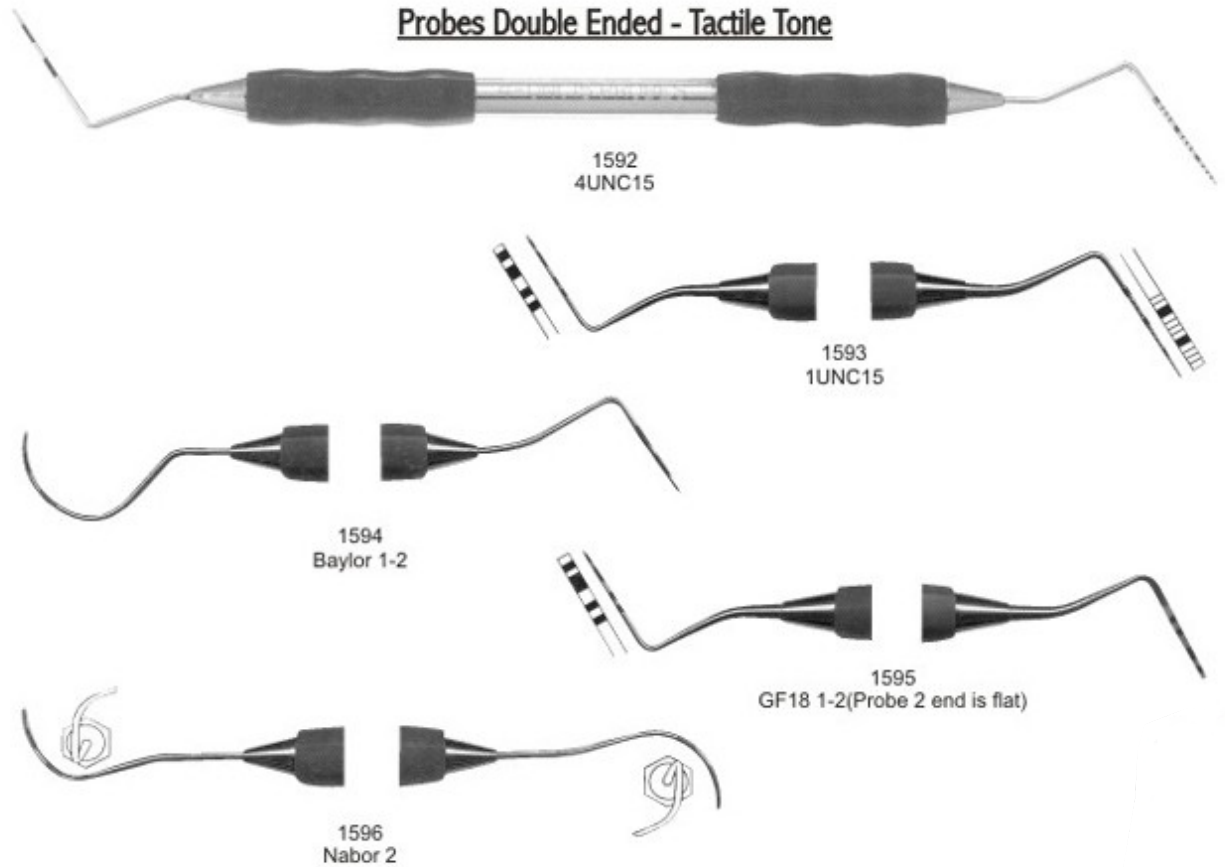



# Probes

Ahmed Pak Impex

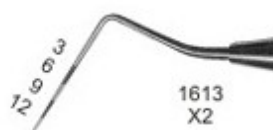
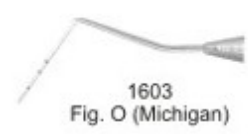
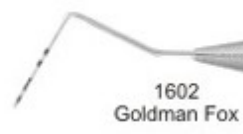
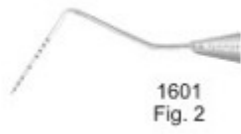
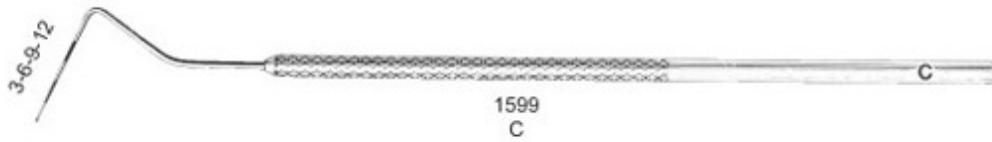
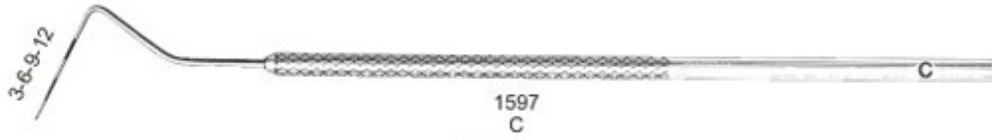





# Probes

Ahmed Pak Impex

## PROBES DOUBLE ENDED STANDARD

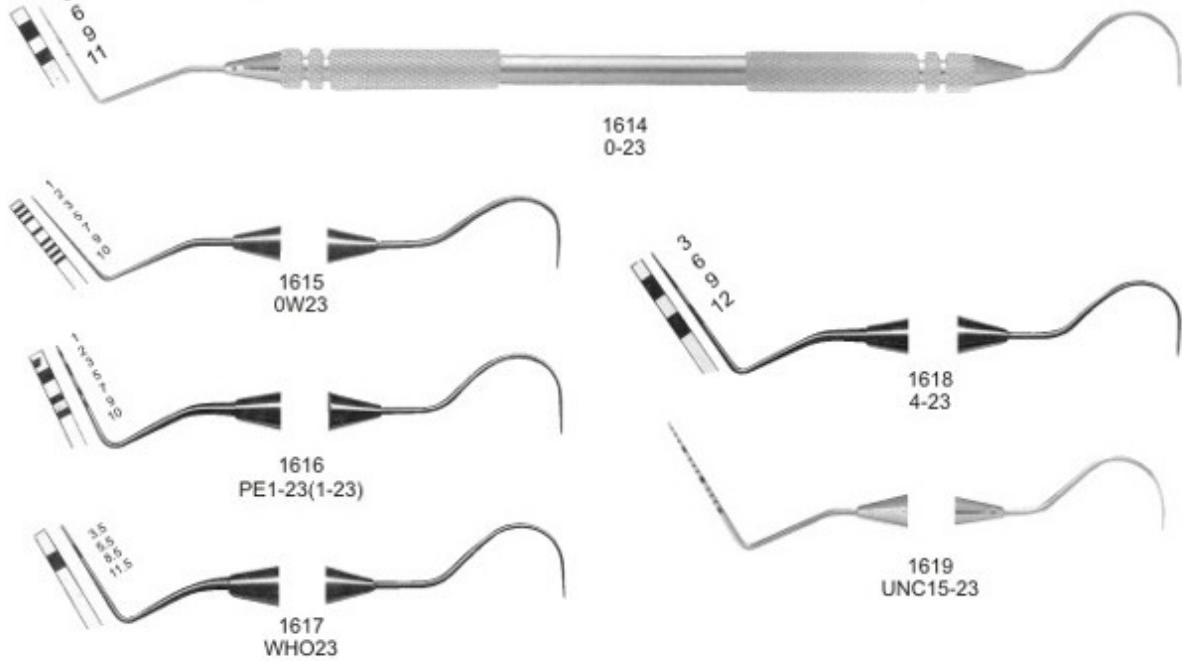

## PROBES DOUBLE ENDED TACTILE TONE

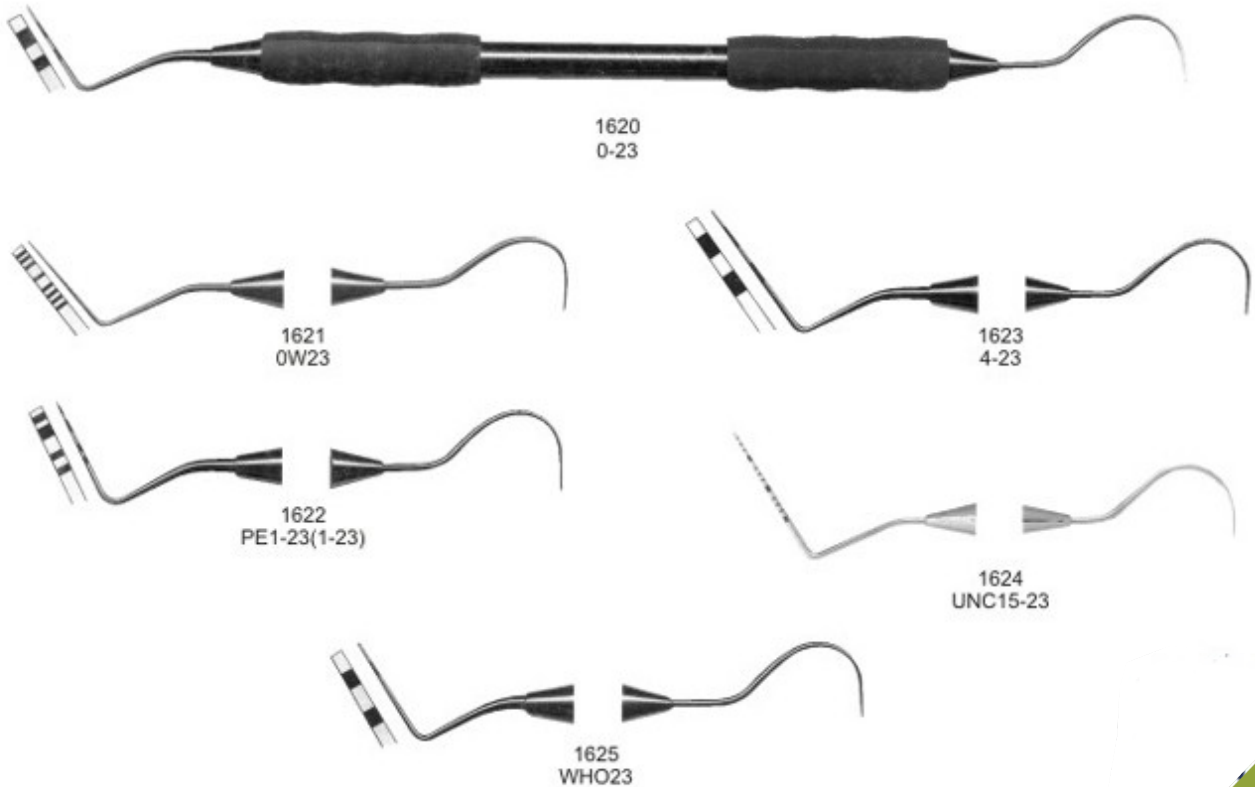



# Endodontic Condensers

Ahmed Pak Impex

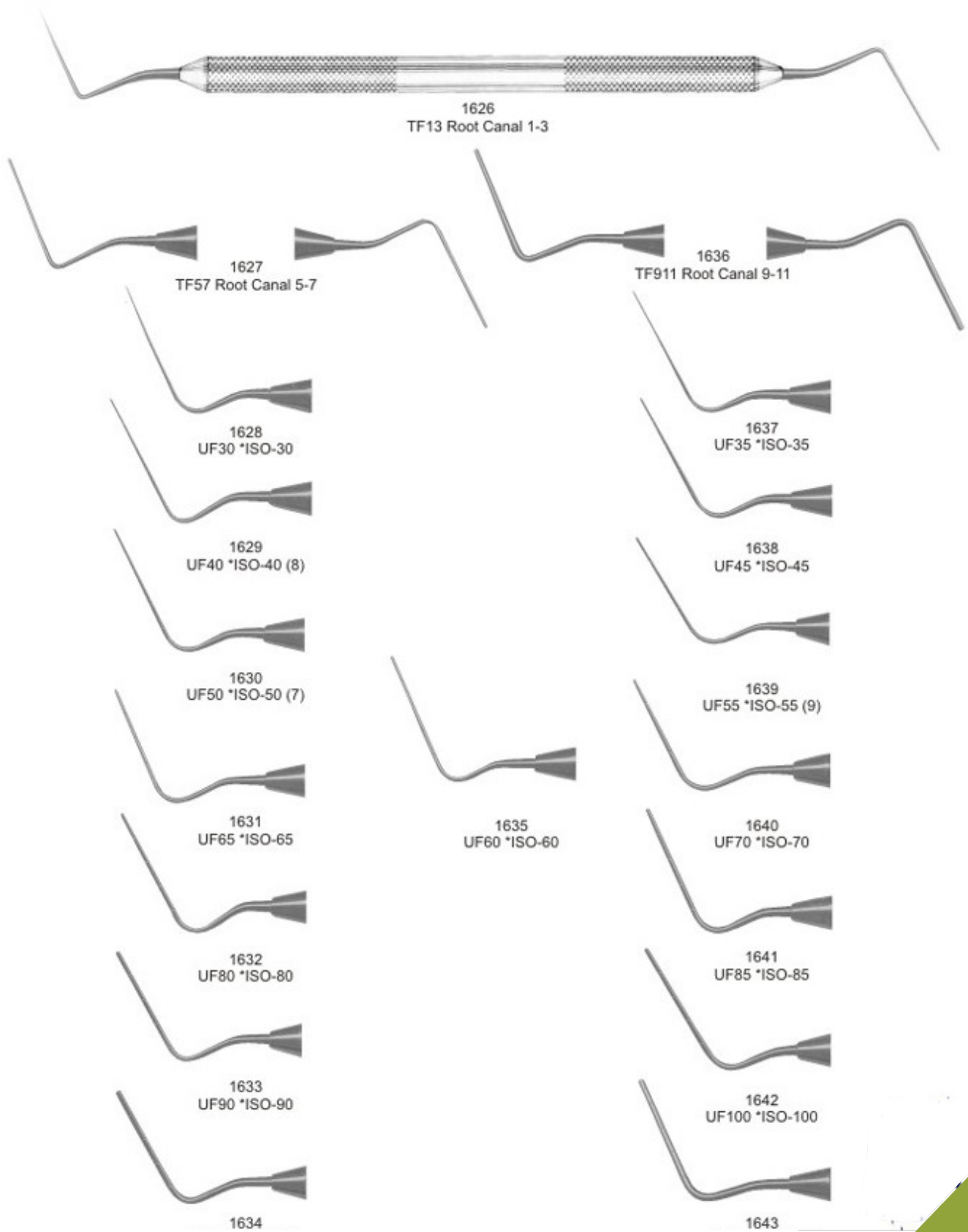



Ahmed Pak Impex

# Endodontic Condensers/Spreaders

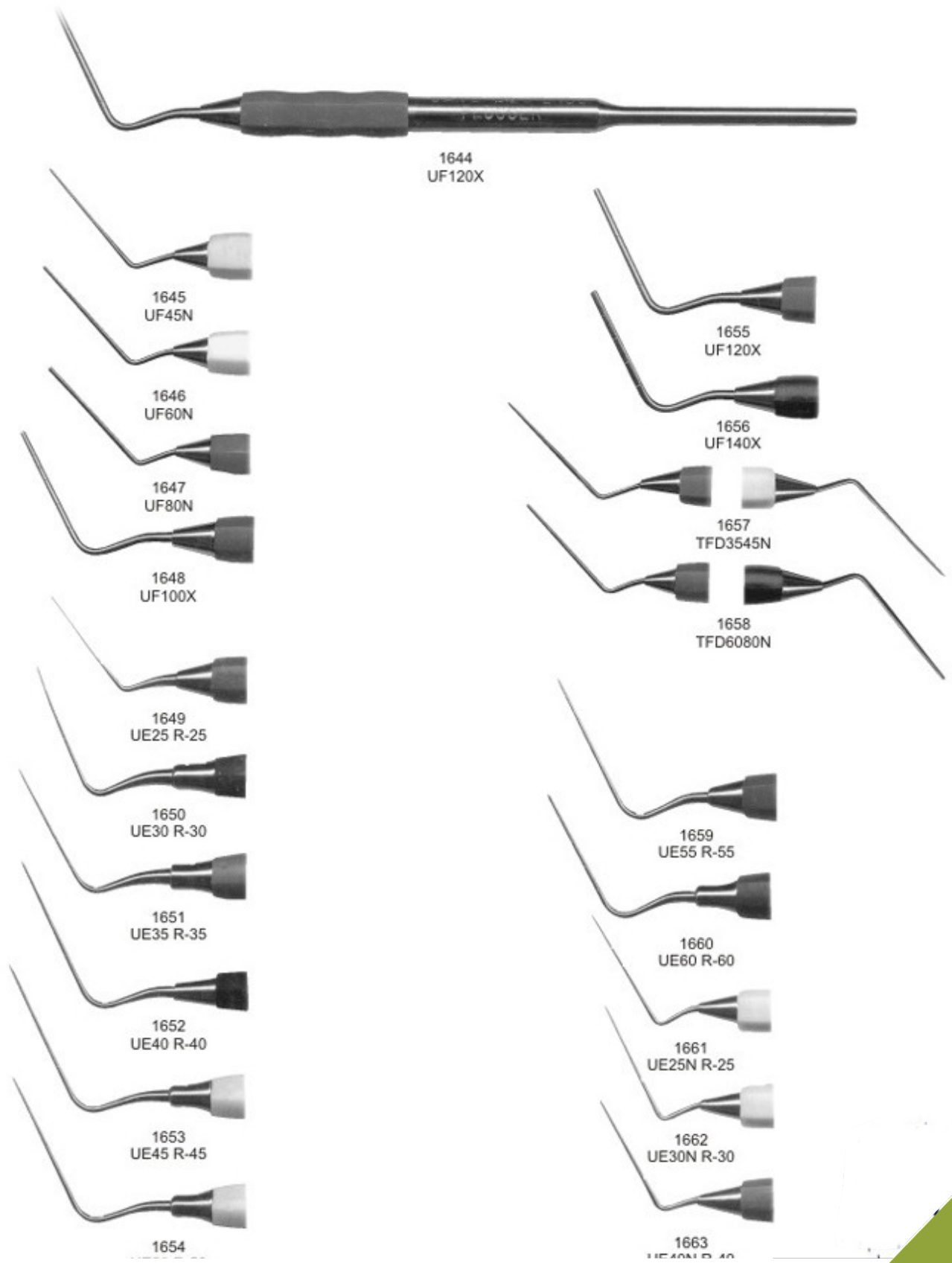

# Obturation Instruments

1664  
No. D11



1665  
No. D11T



1666  
No. KR1



1667  
No. 25S



1668  
No. W1S



1669  
No. W2S



1674  
No. 5, D(1mm).50mm, .55mm D(5mm)  
D(16mm), 85mm, .75mm D(16mm)

1675  
No. 7, D(1mm).70mm, .50mm D(5mm)  
D(16mm), 1.00mm, .75mm D(16mm)

1676  
No. 9, D(1mm)1.00mm, .63mm D(5mm)  
D(16mm), 1.30mm, .75mm D(16mm)

1677  
No. 11, D(1mm)1.20mm, .63mm D(5mm)  
D(16mm), 1.50mm, .75mm D(16mm)

1678  
No.1 (D1 .35mm, D16 .75mm)

1679  
No.2 D1 .55mm, D16 .85mm

1680  
No.3 D1 .85mm, D16 1.15mm

1681  
No.4 D1 1.00mm, D16 1.30mm

1670  
Lucks No.1

1671  
Lucks No.2

1672  
Lucks No.3

1673  
Lucks No.4

1682  
No.1-3 - D1 .25mm/D1 .35mm

1683  
No.3-5 - D1 .35mm/D1 .55mm

1684  
No.5-7 - D1 .55mm/D1 .70mm

1685  
No.9-11 - D1 1.00mm/D1 1.20mm



# Excavators

Ahmed Pak Impex

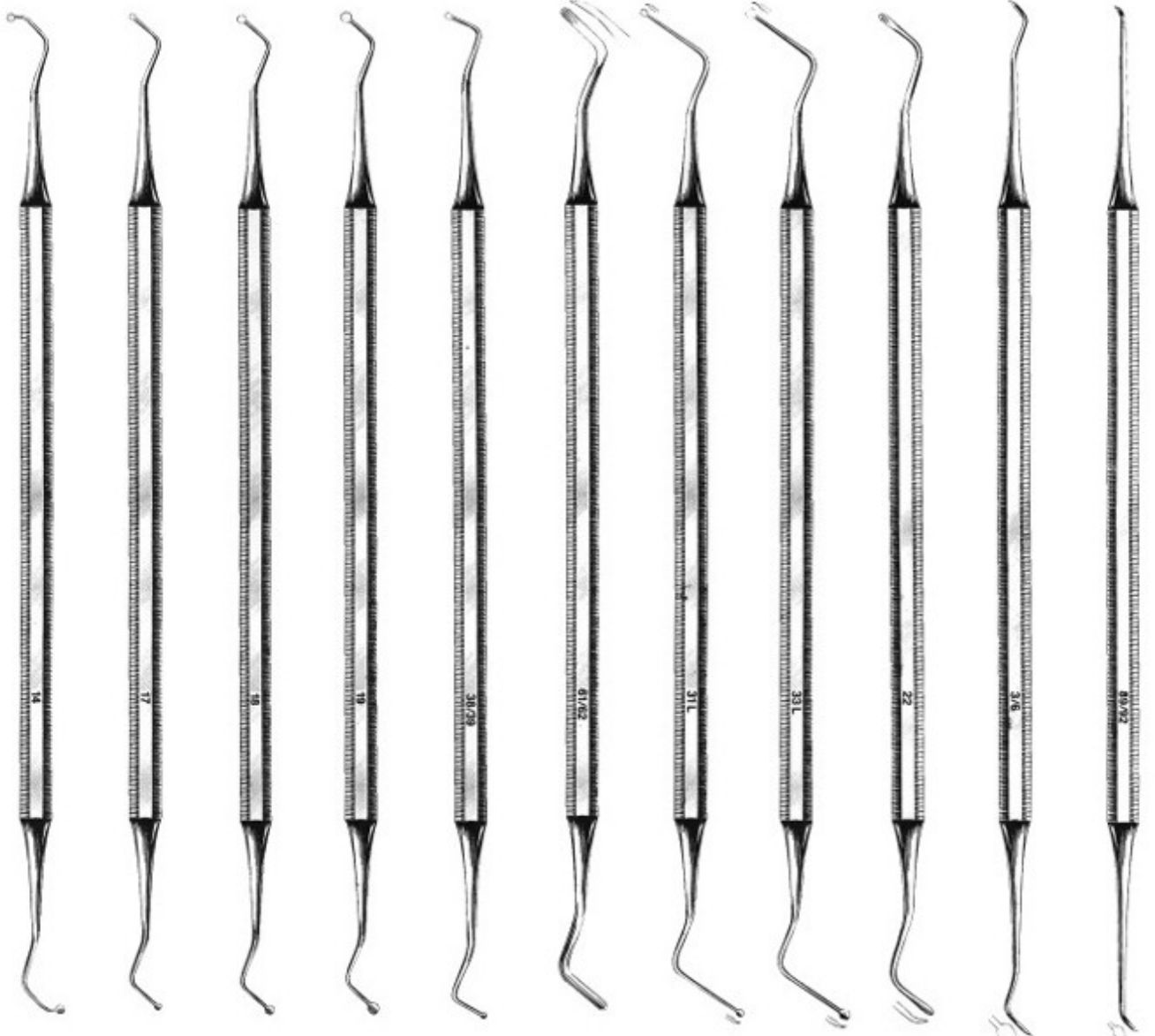

1686 No. 14      1687 No. 17      1688 No. 18      1689 No. 19      1690 No. 38/39      1691 No. 61/62      1692 No. 31L      1693 No. 33L      1694 No. 22      1695 No. 3/6      1696 No. 89/92

# Excavators

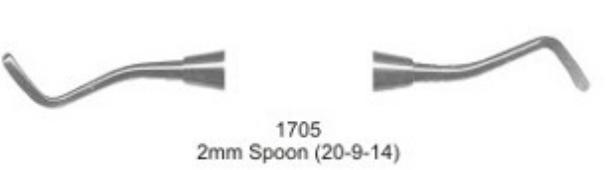
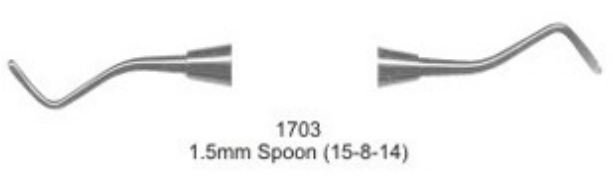
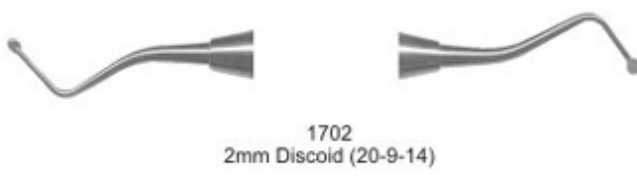
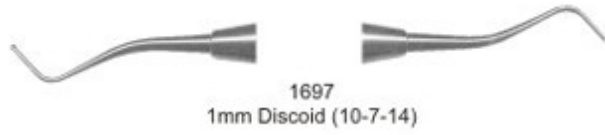

# Excavators, Explorer / Probes

## Excavators

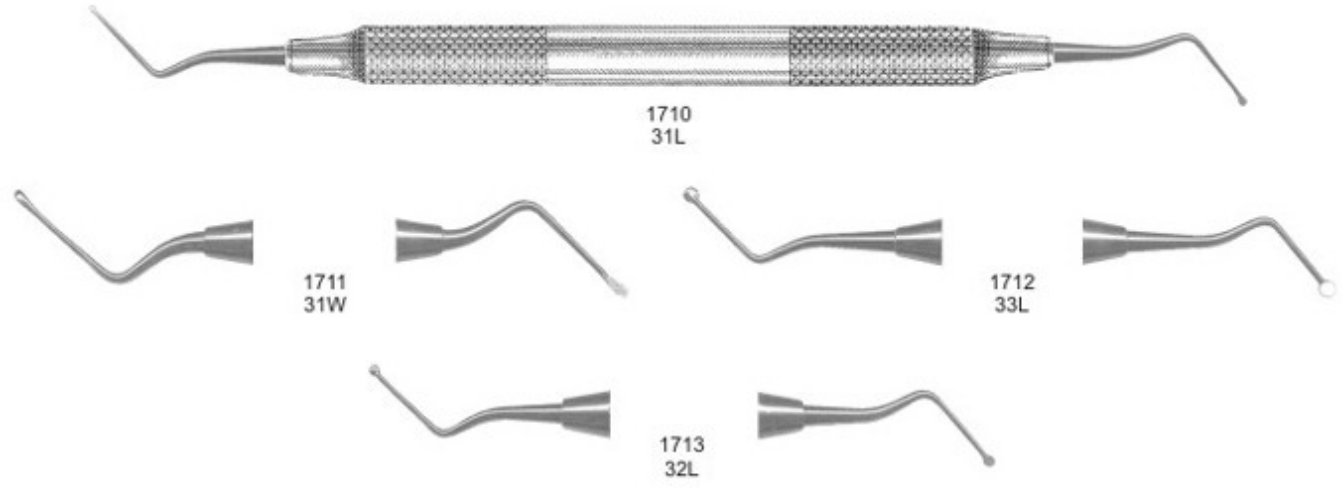

## Explorers / Probes

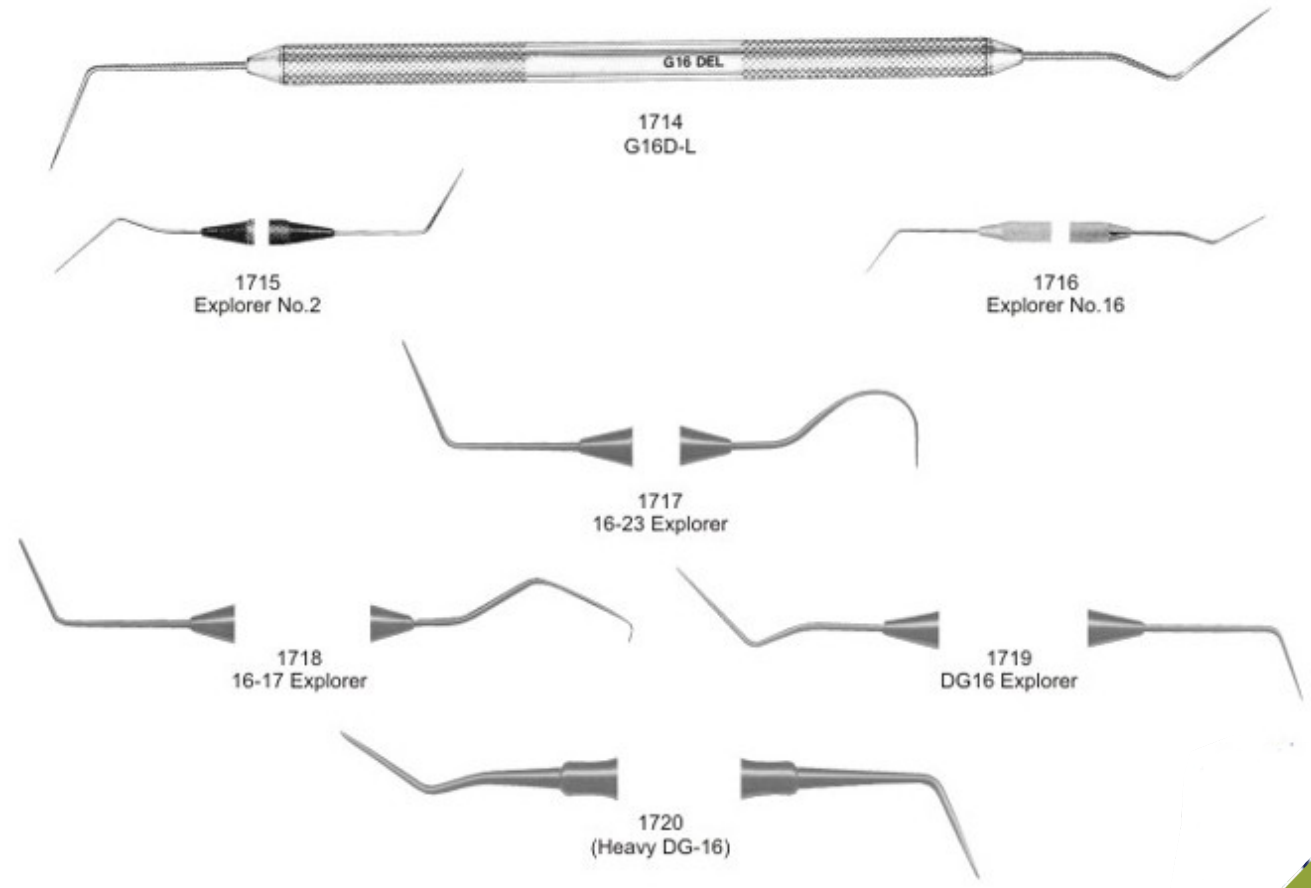



# Explorers

Ahmed Pak Impex





# Explorers

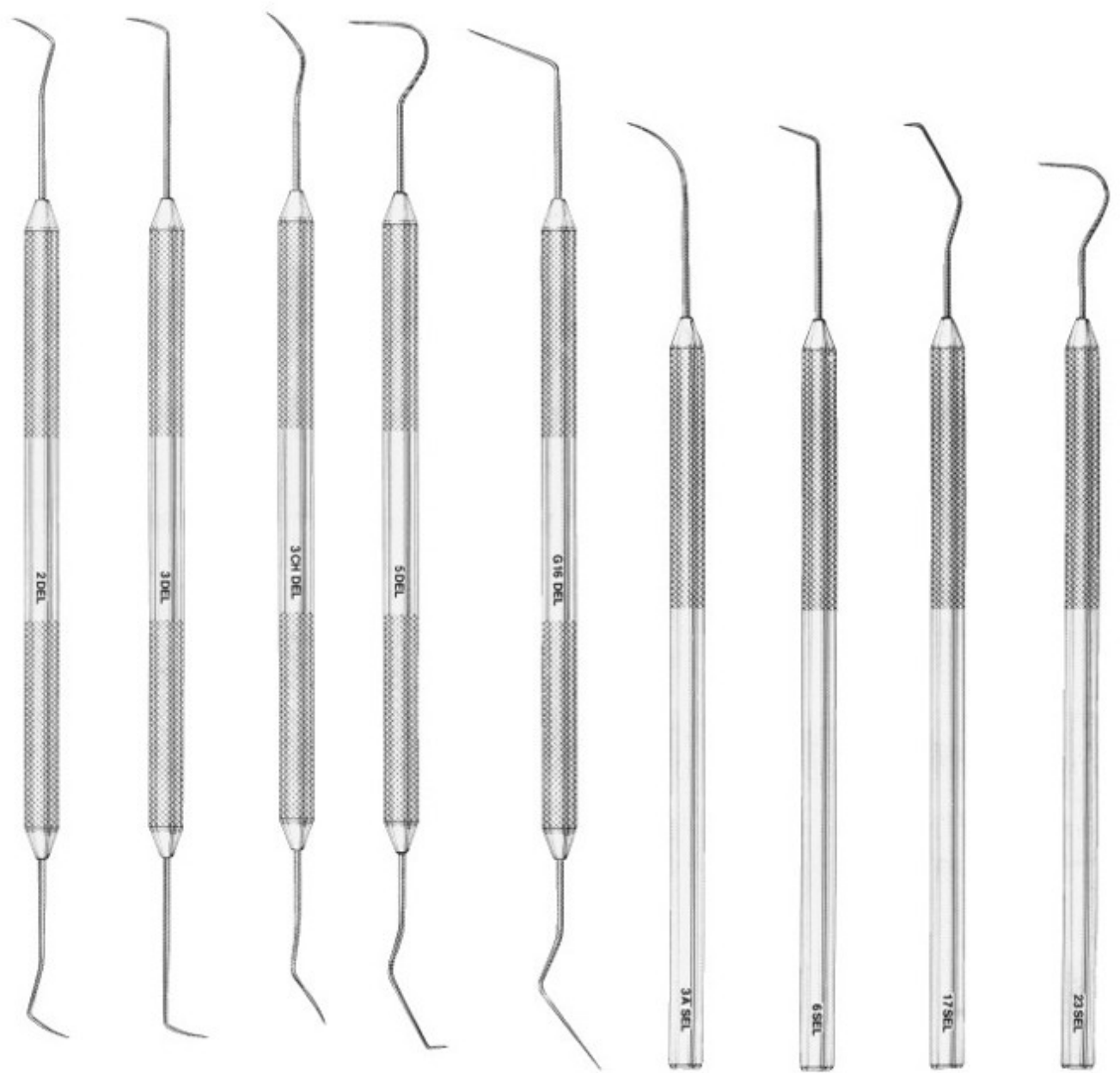

1732 No. 2D-L      1733 No. 3D-L      1734 No. 3CHD-L      1735 No. 5D-L      1736 No. G16D-L      1737 No. 3AS-L      1738 No. 6S-L      1739 No. 17S-L      1740 No. 23S-L



Ahmed Pak Impex

# Explorer / Probe Combination



1741  
Gf17 Probe/Explorer

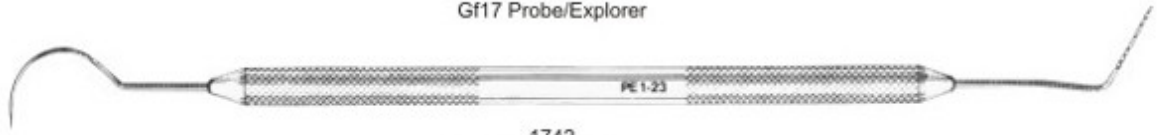

1742  
PE 1-23 Probe/Explorer

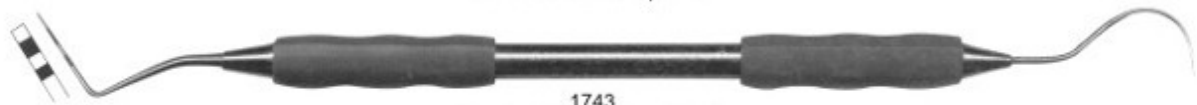

1743  
Probe 0 / 23 Explorer (fine)

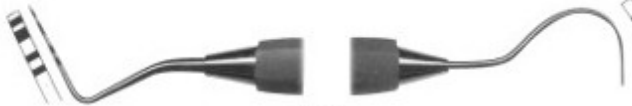

1744  
Probe 1 / 23 Explorer



1746  
Probe 4 / 23 Explorer



1745  
Probe OW / 23 Explorer



1747  
Ball Tip Probe WHO / 23 Explorer

## PROBES



1748  
Gf18 Probe



1749  
"C" Probe

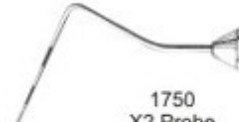

1750  
X2 Probe



1751  
1-2 (Probe 2 end is flat)



1752  
1 UNC 15



1753  
4 SE

# Cord Packers, Hatchets, Hoes

## CORD PACKERS

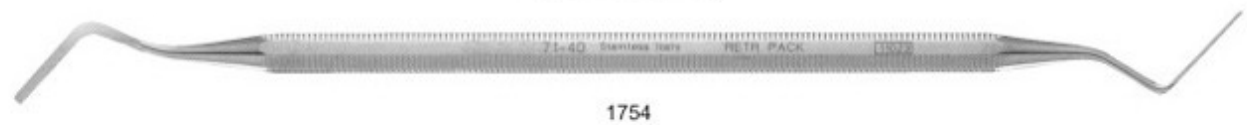

1754

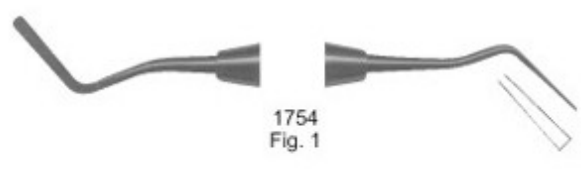

1754  
Fig. 1



1755  
Fig. 2



1756  
Fig. 1



1757  
BLOOMFIELD  
Fig. 2 (off angle)



1758  
CSI-1 (slightly serrated on ends)



## HATCHETS



1759  
1mm (10-7-14)



1760  
1.3mm (13-10-16)



1761  
1.5mm (15-8-14)



## HOES

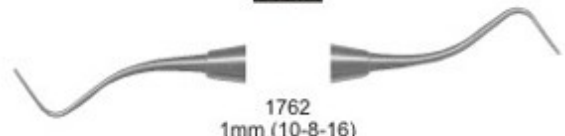

1762  
1mm (10-8-16)



1763  
UWH 18-19



1764  
UWH 16-18



1765  
UWH 20-21

# Amalgam Pluggers / Condensers / Applicators



**1766**  
BEHRMAN (Fig. 1)



**1767**  
BLACK (Fig. 1-2)



**1770**  
Hollenback No.1 Plugger

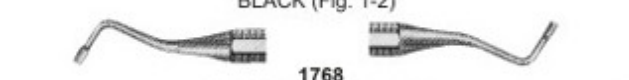

**1768**  
MORQUETTE (Fig. 0/1)

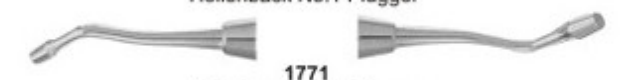

**1771**  
Hollenback No. 2 Plugger

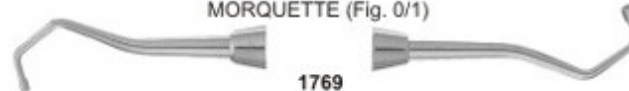

**1769**  
Black Action 11/12 Plugger



**1772**  
Hollenback No. 3 Plugger



**1773**  
Blacks 0-1 (1mm-1.5mm)



**1774**  
Blacks 1-2 (1.5mm-2.5mm)



**1779**  
.7mm-1mm



**1775**  
Bodkin 1 (.7mm-1mm)



**1780**  
1mm-1.5mm

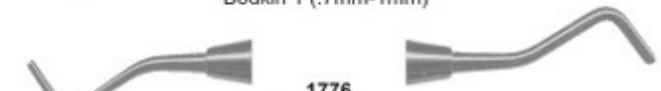

**1776**  
Bodkin 2 (1.5mm-2mm)



**1781**  
1.5mm-2mm



**1777**  
2.5mm-3mm



**1782**  
Oregon (Fig. 3)

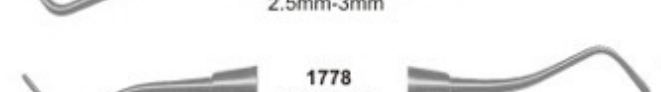

**1778**  
Oregon 2



**1783**  
Oregon (Fig. 4)



**1784**  
UP 12



**1785**  
Applicator 1-2



**1786**  
Birtles Applicator Spatula



**1787**  
Birtles Applicator Spatula K

# Burnishers



1788  
Fig. 1



1789  
Fig. 28/29

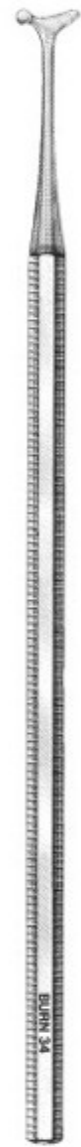

1790  
Fig. 34



1791  
Fig. 27/29



1792  
Fig. 21B



1793  
ACORN  
Fig. 21



# Amalgam Guns & Carriers

Ahmed Pak Impex

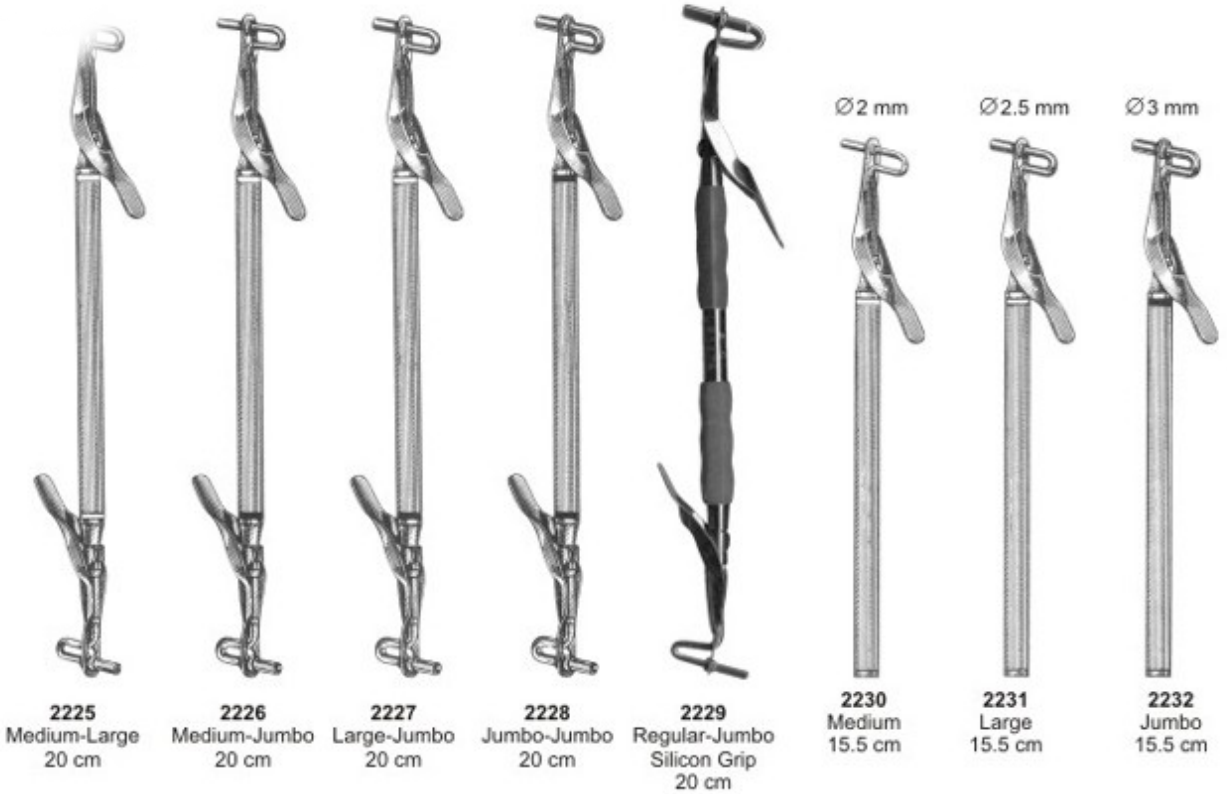

**2225**  
Medium-Large  
20 cm

**2226**  
Medium-Jumbo  
20 cm

**2227**  
Large-Jumbo  
20 cm

**2228**  
Jumbo-Jumbo  
20 cm

**2229**  
Regular-Jumbo  
Silicon Grip  
20 cm

Ø 2 mm

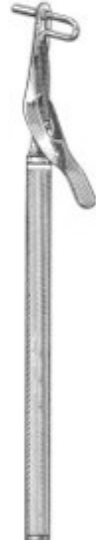

**2230**  
Medium  
15.5 cm

Ø 2.5 mm



**2231**  
Large  
15.5 cm

Ø 3 mm



**2232**  
Jumbo  
15.5 cm

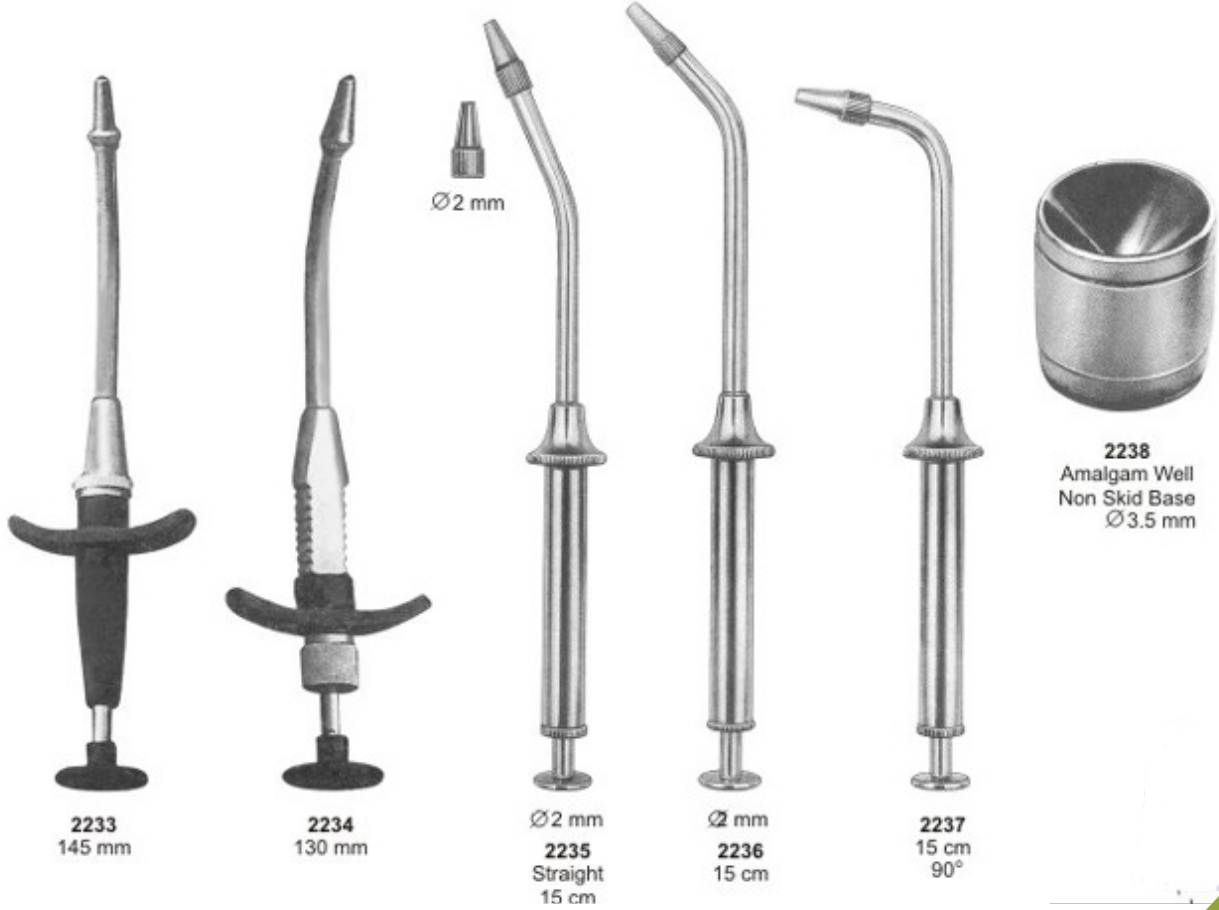

**2233**  
145 mm

**2234**  
130 mm

Ø 2 mm

Ø 2 mm  
**2235**  
Straight  
15 cm

Ø 2 mm  
**2236**  
15 cm

**2237**  
15 cm  
90°



**2238**  
Amalgam Well  
Non Skid Base  
Ø 3.5 mm

# Retainers, Bands, Strip Holder Clips, Napkin Holders

## Retainers

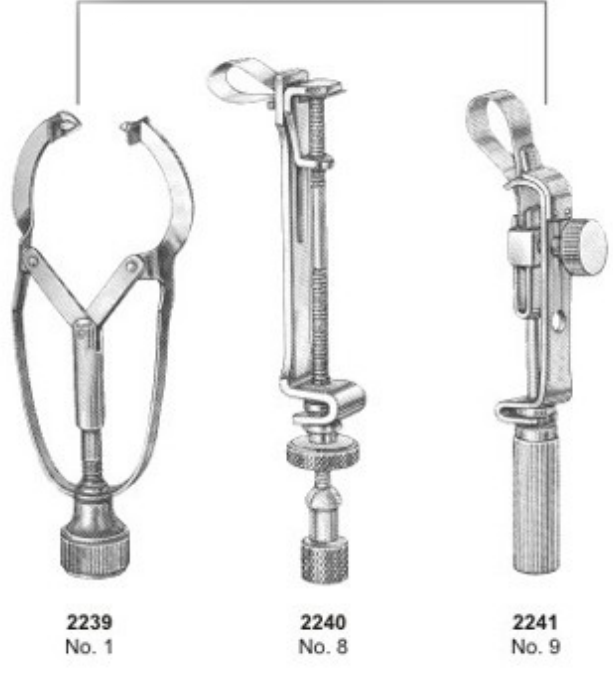

## "Tofflemire" Type Retainers



## Tofflemire Bands

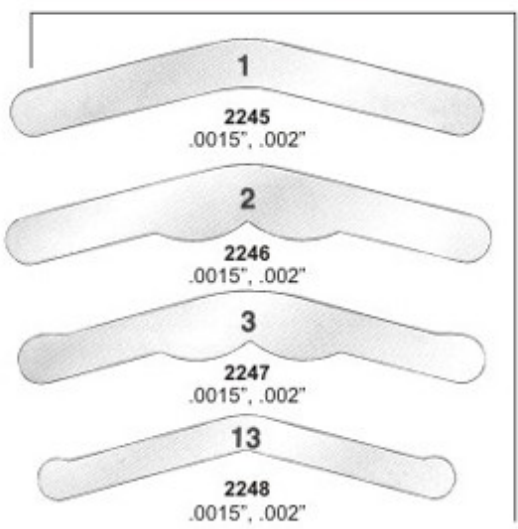

## Napkin Holders



## Strip Holders

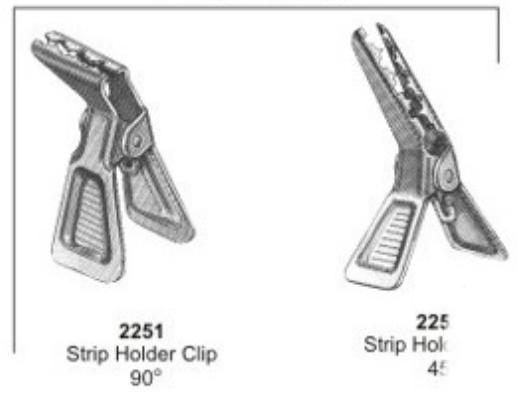



Ahmed Pak Impex

# Rubber Dam Instruments



**2253**  
IRORY  
Light weight, 170 mm



**2254**  
BREWER  
175 mm



**2255**  
BREWER  
175 mm



**2256**  
WHITE  
175 mm



**2257**  
IVORY  
170 mm



**2258**  
AINSWORTH  
Rubber Dam Punch  
170 mm



**2259**  
AINSWORTH  
Rubber Dam Punch  
170 mm



**2260**  
AINSWORTH  
Rubber Dam Punch  
170 mm

## Articulating Paper Forceps



**2264**  
MILLER  
Articulating  
Forceps  
15 cm



**2266**  
MIL  
Art  
Fo  
15



**2261**  
"IV" Type  
Rubber Dam Punch  
160 mm



**2262**  
Plastic Rubber Dam  
Frame 242

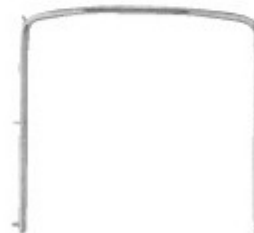

**2263**  
Rubber Dam Holder  
Stainless Steel Pins



# Rubber Dam Clamps

## MOLARS



**2266**  
76D-W3



**2267**  
76D-3



**2272**  
76D-7A



**2273**  
76D-7



**2278**  
76D-12A



**2279**  
76D-13A



**2284**  
76D-26



**2285**  
76D-28



**2288**  
76D-W8A



**2289**  
76D-8A



**2290**  
76D-10



**2291**  
76D-11



**2294**  
76D-24



**2295**  
76D-25

## UPPER MOLARS



**2268**  
76D-4



**2269**  
76D-5



**2274**  
76D-8



**2275**  
76D-26N



**2280**  
76D-30



**2281**  
76D-31



**2286**  
76D-201



**2287**  
205

## MOLARS



**2292**  
76D-14



**2293**  
76D-118



**2296**  
76D-27



**2297**  
76D-56



**2298**  
76D-14A

## PREMOLARS

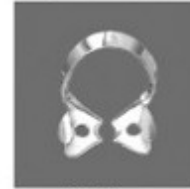

**2270**  
76D-0



**2271**  
76D-1



**2276**  
76D-2A



**2277**  
76D-2



**2282**  
76D-27N



**2283**  
76D-29

## ANTERIOR



**2299**  
76D-00



**2300**  
76D-1A



**2301**  
76D-9



**2302**  
76D-212



# Aspirating Syringes

Ahmed Pak Impex



4969/CO

4969/F

4969/CV



**2303**  
ml 1,8  
EU



**2304**  
ml 1,8  
EU/AM



**2305**  
ml 1,8  
EU/AM



**2306**  
Fig. 1  
ml 1,8  
EU



**2307**  
Fig. 1  
ml 1,8  
EU



**2308**  
SS INOX  
All inox & autoclavable  
black plastic handle  
passive automatic  
aspiration.



**2309**  
Fig. 1  
ml 1,8  
EU/Am



**2310**  
Fig. 1  
ml 1,8  
EU/Am



**2311**  
Fig. 1  
ml 1,8  
EU/Am





# Syringes

Ahmed Pak Impex

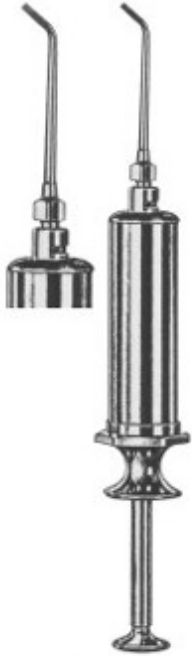

**2313**  
Water Syringe  
complete with  
1 cannula (Lure-Lock)



**2314**  
Water Syringe  
complete with  
1 cannula (Lure-Lock)



**2315**  
Metal Water Syringe  
self-filling, with 1  
cannula (Lure-Lock)



**2316**  
Sparrel Barrel with  
plunger suitable for  
syringes



**2317**  
Cannula, only, with  
Luer-Lock connector  
suitable for syringes



**2318**  
Articulating Barrel Syringe



**2319**  
ml 1,8



**2320**  
ml 1,8



**2323**  
Fig. 1  
ml 1,8 EU



**2321**  
Fig. 1  
ml 1,8



**2322**  
Fig. 1  
ml 1,8 EU

# Dental Tweezers



**2324**  
PERRY  
13 cm



**2325**  
ADSON  
12 cm



**2326**  
MICRO ADSON  
15 cm



**2327**  
STANDARD  
14, 18, 25 cm



**2328**  
CUSHING  
18 cm



**2329**  
Curved



**2330**  
SELECT  
15, 18, 20 cm



**2331**



**2332**  
MCINDOE  
15 cm



**2333**  
GILLIES  
15 cm



**2334**  
WAUGH  
15, 20 cm



**2335**  
K  
1

# Dental Tweezers



**2336**  
COLLEGE  
15 cm



smooth



**2337**  
COLLEGE  
15 cm



serrated



**2338**  
COLLEGE  
15 cm



smooth



**2339**  
COLLEGE  
15 cm



serrated



**2340**  
COLLEGE



smooth



**2341**  
COLLEGE



serrated



**2342**  
COLLEGE



smooth



**2343**  
COLLEGE



serrated

# Dental Tweezers



**2344**  
MERIAM  
16 cm



smooth



**2345**  
MERIAM  
16 cm



serrated



**2346**  
MERIAM  
16 cm



smooth



**2347**  
MERIAM  
16 cm1



serrated



**2348**  
MERIAM  
16 cm



smooth



**2349**  
MERIAM  
16 cm



serrated



**2350**  
MERIAM  
16 cm



smooth



**2351**  
MERIAM  
16 cm



serrated



# Dental Tweezers

Ahmed Pak Impex

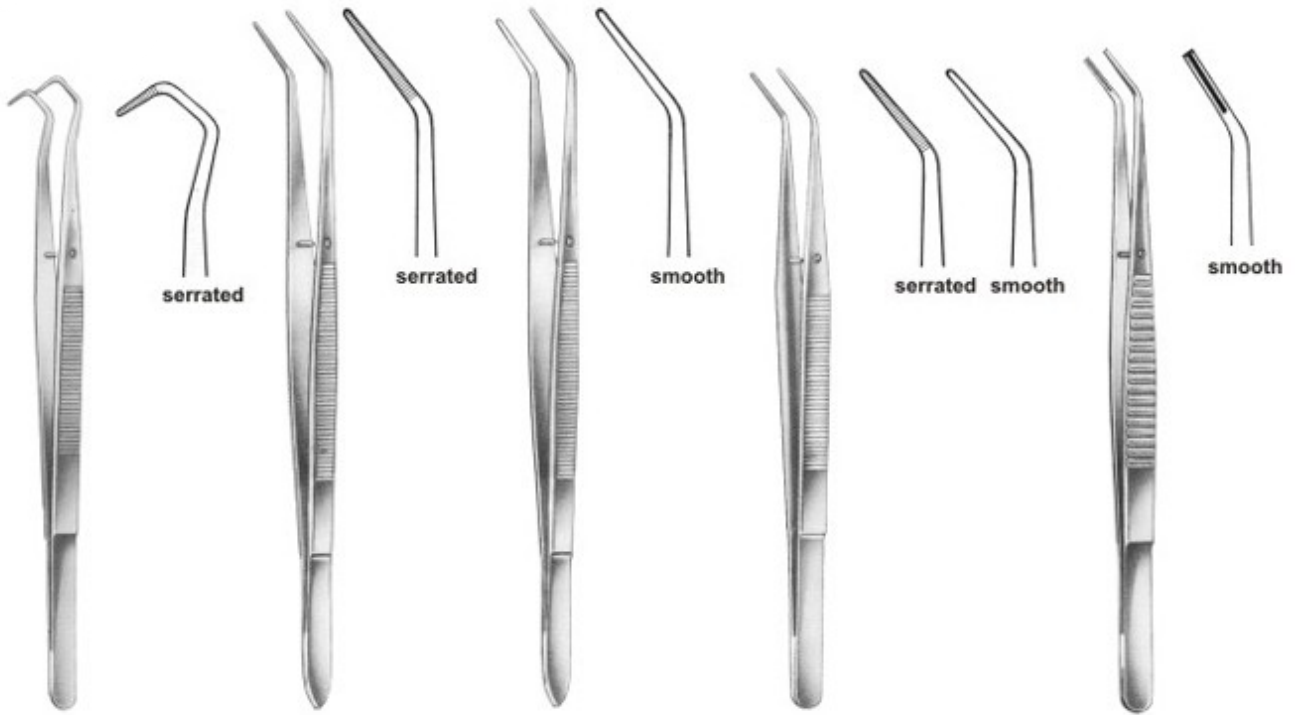

**2352**  
COLLEGE  
14.5 cm, 5<sup>3</sup>/<sub>4</sub>"

**2353**  
FLAGG  
16 cm, 6<sup>1</sup>/<sub>4</sub>"

**2354**  
FLAGG  
16 cm, 6<sup>1</sup>/<sub>4</sub>"

**2355**  
LANDGRAF  
15 cm, 6"

**2356**  
15.5 cm, 6<sup>1</sup>/<sub>8</sub>"

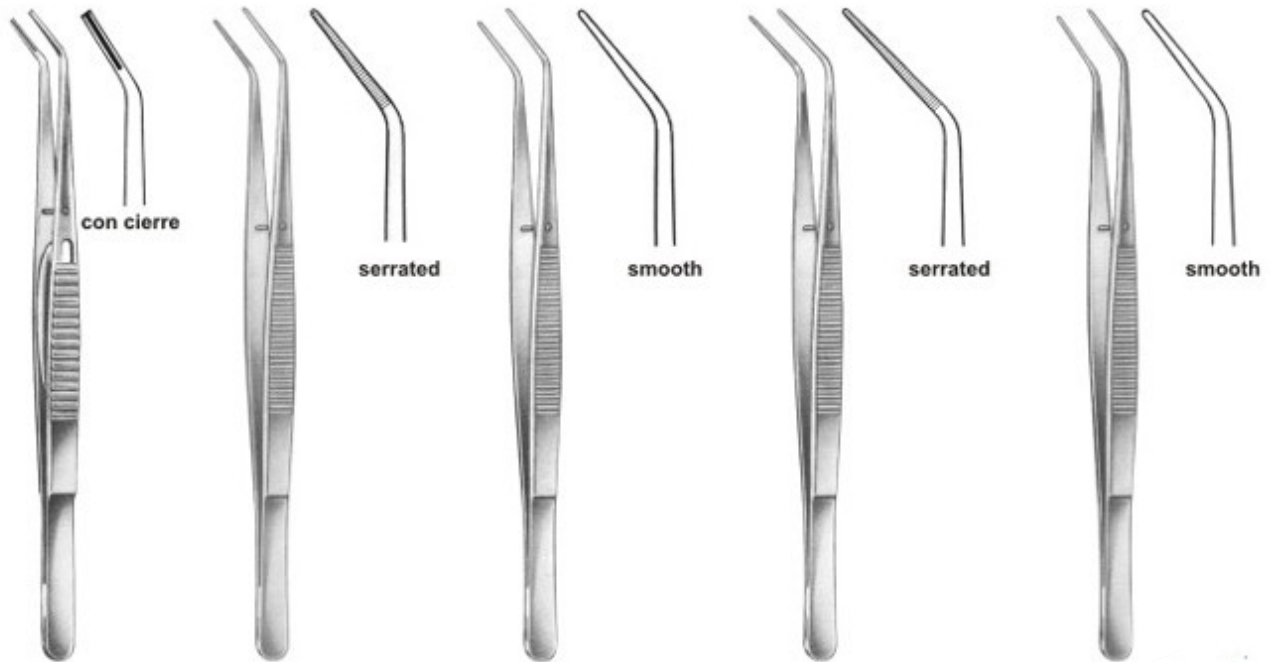

**2357**  
15.5 cm, 6<sup>1</sup>/<sub>8</sub>"

**2358**  
LONDON-COLLEGE  
15 cm, 6"

**2359**  
LONDON-COLLEGE  
15 cm, 6"

**2360**  
LONDON-COLLEGE  
15 cm, 6"

**2361**  
LONDON-CO  
15 cm, 6"

# Dental Tweezers



**2362**  
LONDON-COLLEGE  
15 cm, 6"



**2363**  
LONDON-COLLEGE  
15 cm, 6"

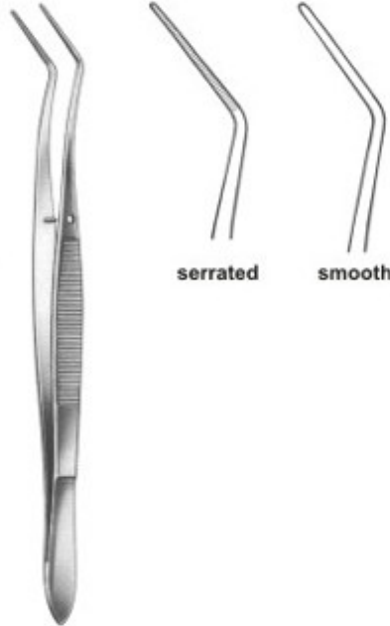

**2364**  
MERIAM  
16 cm, 6 1/4"



**2365**  
ALLEN  
18 cm, 7 1/8"



**2366**  
ALBRECHT  
16 cm, 6 1/4"



**2367**  
ALBRECHT  
16 cm, 6 1/4"



**2368**  
16 cm, 6 1/4"



**2369**  
16 cm, 6 1/4"

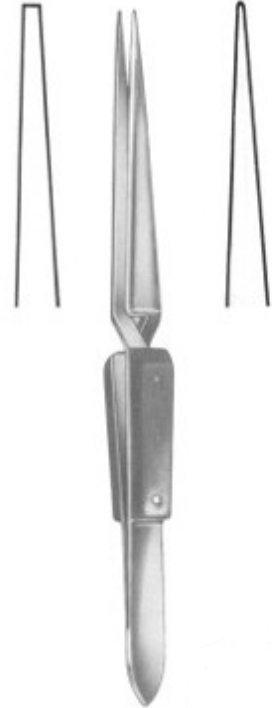

**2370**  
16 cm, 6"



# Sterilizing & Lab Instruments



**2371**  
DAVIS  
6"

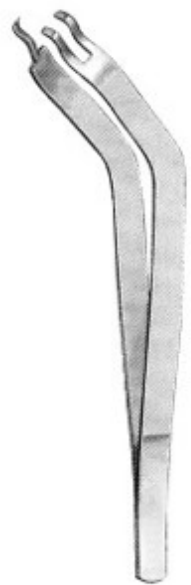

**2372**  
Grasping Forceps  
6 1/4"



**2373**  
Mesh Bur & Diamond Holder  
Large, 2 1/8" Diameter



**2374**  
Soldering Tweezers  
6 1/4"



**2375**  
Narrow Fine  
4 3/4"



**2376**  
Super Fine  
4 3/8"



**2377**  
Fine Curved  
4 1/2"



**2378**  
Bonding Bracket  
Holder  
136 mm



**2379**  
Bonding Bracket  
Holder  
135 mm



**2380**  
Bonding Bracket  
Holder  
135 mm



**2**



# Endodontic Forceps

Ahmed Pak Impex



**2382**  
Endo Forceps  
4 3/4"



**2383**  
PEETS Forceps  
4 3/4", Useful For  
Removing Broken  
Instruments

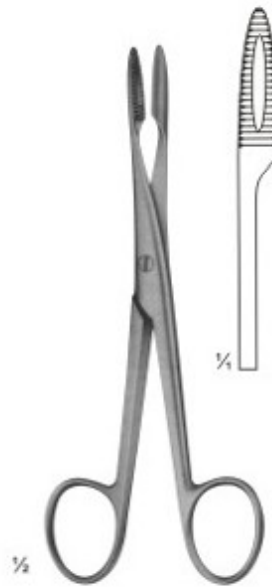

**2384**  
Without Ratchet  
145 mm

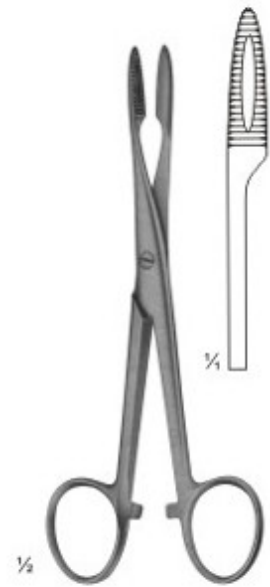

**2385**  
With Ratchet  
145 mm



**2386**  
CRILE  
140 mm

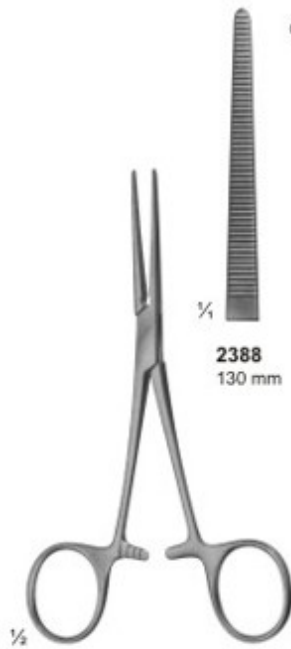

**2387**  
PEAN  
Slender type

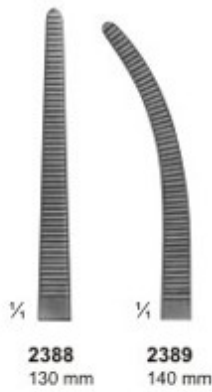

**2388**  
130 mm



**2389**  
140 mm

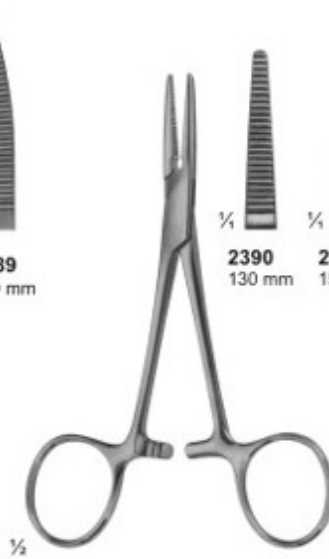

**2390**  
SPENCER-WELLS

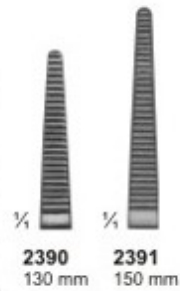

**2390**  
130 mm

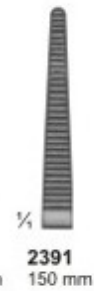

**2391**  
150 mm

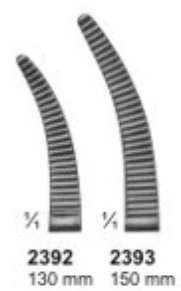

**2392**  
130 mm



**2393**  
150 mm



# Tissue Forceps

Ahmed Pak Impex



**2394**  
BABY-ALLIS  
5", Straight  
4x5 teeth extra delicate



**2395**  
ALLIS  
6", Straight  
4x5 teeth extra delicate



**2396**  
ALLIS  
6", Straight  
4x5 teeth extra delicate



**2397**  
1x2 teeth  
6"



**2398**  
SEMKIN  
6", Straight,  
1x2 teeth



**2399**  
ADSON  
4 3/4"  
1x2 teeth



**2400**  
BROWN-ADSON  
4 3/4"  
7x7 teeth



**2401**  
BROWN  
6"  
8x8 teeth



**2402**  
RUSSIAN  
6"  
8x8 teeth



**2403**  
Extra-Delicate,  
Straight, 4"

# Hemostatic Forceps, Towel Clamps, Napkin Holders



**2404**  
HALSTED-MOSQUITO  
Straight, Curved, 5"



**2405**  
HALSTED-MOSQUITO  
Straight, Curved, 5"  
1x2 teeth



**2406**  
HALSTED-MOSQUITO  
Jaws 45 Angled on Flat, 5"  
Extra Delicate



**2407**  
KELLY  
5 1/2", Straight



**2408**  
JONES  
3 1/2"



**2409**  
BACKHAUS  
3 1/2"



**2410**  
BACKHAUS  
5 1/4"



**2411**  
LORNA  
Non Perforated  
3 1/2"



## Retractors, Depressors, Mouth Gags

Ahmed Pak Impex



**2412**  
WEITLANER  
Sharp  
130 mm

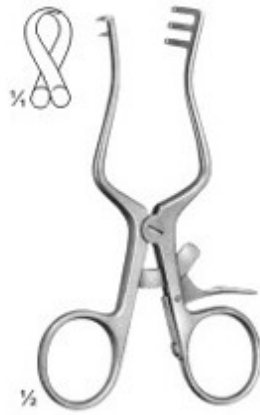

**2413**  
WEITLANER  
Sharp  
110 mm



**2414**  
WEITLANER  
Semi-Sharp  
110 mm



**2416**  
ANDREWS  
Tongue Depressor,  
Serrated Blade 21 mm  
wide

**2415**  
WIEDER  
Tongue Depressor,  
Small Blade 28 mm Wide  
Serrated



**2417**  
MOLT  
Pediatric



**2418**  
MOLT  
Child



**2419**  
MOLT  
Adult



**2420**  
DENH

# Lip & Cheek Retractors



2421  
140 mm



2422  
BRUENINGS  
190 mm



2423



2424



2425



2426



2427



2428



2429



# Lip & Cheek Retractor

Ahmed Pak Impex



**2430**  
LANGENBECK  
210 mm



**2431**  
KOCHER-LANGENBECK  
215 mm



**2432**  
BUCHS  
205 mm



38 x 18 mm



**2433**  
KOCHER  
230 mm



**2436**  
MIDDELDORPF



**2434**  
15 x 15 mm  
220 mm



**2435**  
20 x 22 mm  
215 mm



**2437**  
28 x 28 mm  
235 mm



**2438**  
KOCHER  
230 mm



**2439**  
COLLIN  
150 mm



**2440**  
ROUX  
Set  
165 mm



Ahmed Pak Impex

## Tissue Retractors & Hooks



**2441**  
3 sharp prongs



**2442**  
2 sharp prongs  
6"



**2443**  
2 sharp prongs  
6"



**2444**  
FOMON  
145 mm



**2445**  
ALM  
70 mm



**2446**  
SENN  
3 sharp prongs  
6 3/8"



**2447**  
TOENNIS  
Dura Retractor  
150mm



**2448**  
JOSEPH  
165 mm



**2449**  
GILLIES  
180 mm





Ahmed Pak Impex

# Orthodontic Pliers



**2450**  
Fig. 101  
Wire Bending



**2451**  
Fig. 118  
PEESO  
Collar



**2452**  
Fig. 417  
Crown Shell

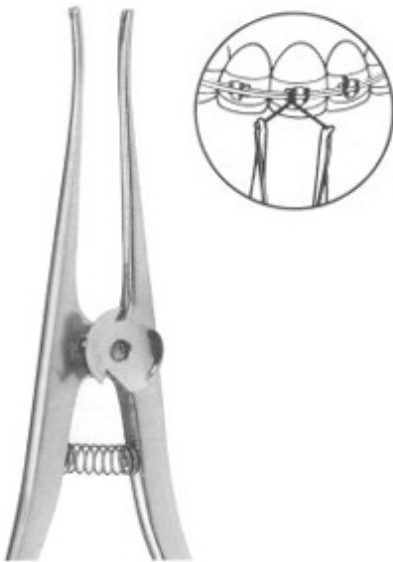

**2453**  
STEINER  
150 mm  
Ligature Pliers

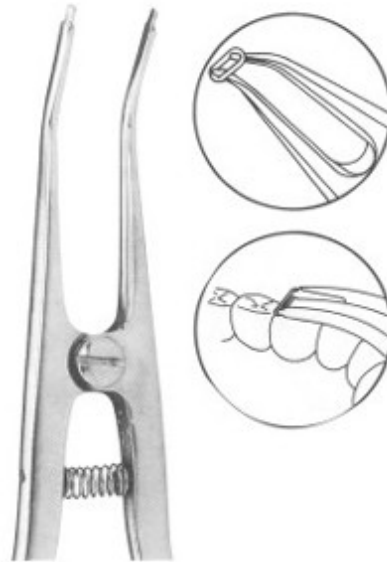

**2454**  
Separating Pliers Elastics  
150 mm



**2455**  
121-Lab & Office

# Orthodontic Pliers



**2456**  
How Plier-Titanium Alloy  
With special coated beaks



**2457**  
How Plier  
Tips are 1/8"(3.2mm)  
diameter



**2458**  
How Plier  
Tips are 1/8"(3.2mm)  
diameter



**2459**  
How Plier-Small  
Tips are 3/32"(2.4mm)  
diameter



**2460**  
How Plier-Offset  
Tips are 1/8"(3.2mm)  
diameter



**2461**  
Weingart Utility Plier  
-Titanium Alloy  
with special coated beaks

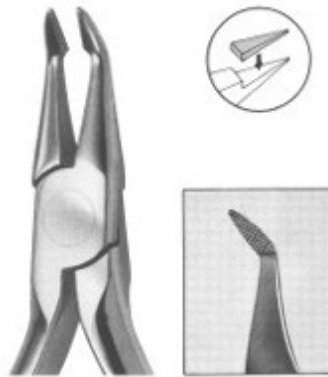

**2462**  
Weingart Utility Plier  
New type of the Weingart Utility Plier  
designed for a more precise operation.



**2463**  
Weingart Utility Plier



**2464**  
Weingart Utility Plier

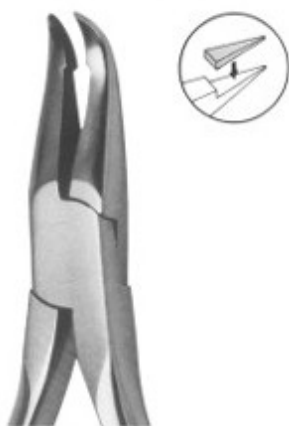

**2465**  
Weingart Utility Plier

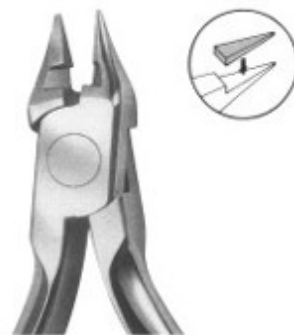

**2466**  
Bird Beak Plier With Cutter  
**Maximum Bending & Cutting Capacity:**  
Wires up to .032"



**2467**  
Bird Beak Plier  
**Maximum Bending Capacity:**  
Wires up to .032"



**2468**  
Bird Beak Plier



# Orthodontic Pliers

Ahmed Pak Impex



**2471**  
TWEED (Fig. 98)  
13 cm, 5 1/8"  
Tweed Loop Omega Pliers.



**2469**  
TWEED - (Fig. 90)  
14 cm, 5 1/2"



**2470**  
O'BRIEN - (Fig. 97)  
14 cm, 5 1/2"



**2472**  
TWEED (Fig. 96)  
14 cm, 5 1/2"



**2473**  
TWEED (Fig. 95)  
13.5 cm, 5 1/4"



**2474**  
SCHWARZ (Fig. 29)  
12.5 cm, 5"



**2475**  
NANCE (Fig. 80)  
13 cm, 5 1/8"



**2476**  
YOUNG (Fig. 55)  
13 cm, 5 1/8"



**2477**  
SCHWARZ (Fig. 30)  
13 cm, 5 1/8"



**2478**  
Optical Plier (Fig. 53)  
14 cm, 5 1/2"

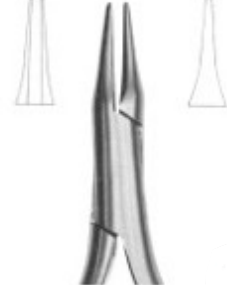

**2479**  
Schwarz (Fig. 7)  
13.5 cm, 5 1/4"



# Orthodontic Pliers

Ahmed Pak Impex



**2480**  
NANCE (Fig. 56)  
12.5 cm, 5"  
Wire bending Pliers



**2487**  
Fig. 70  
14 cm, 5 1/2"  
Wire Contouring Plier



**2481**  
JOHNSON (Fig. 59)  
13.5 cm, 5 1/4"  
Contouring Plier.



**2483**  
De La Rosa (Fig. 34)  
12.5 cm, 5"  
Contouring Plier, Non-Grooved

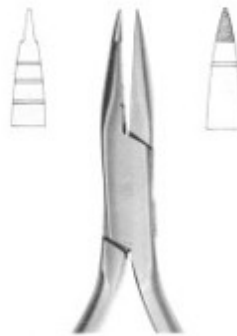

**2485**  
JARABAK (Fig. 20)  
14 cm, 5 1/2"  
Light Wire Bending Plier



**2488**  
Frevert/Tweed (Fig. 51)  
12.5 cm, 5"  
Tweed Arch Plier/Standard Jaw



**2482**  
REYNOLDS (Fig. 61)  
13 cm, 5 1/8"  
Contouring Plier.



**2484**  
De La Rosa (Fig. 35)  
12.5 cm, 5"  
Contouring Plier, Grooved



**2486**  
Fig. 58  
12.5 cm, 5"  
Lingual Arch Bending Plier



**2489**  
ANGLE (Fig. 52)  
13 cm, 5 1/8"  
Arch Forming Pliers

# Orthodontic Pliers



**2490**  
Fig. 60  
13 cm, 5 1/8"  
Wire & Clasp Bending Pliers



**2491**  
Fig. 60  
13 cm, 5 1/8"  
Wire & Clasp Bending Pliers

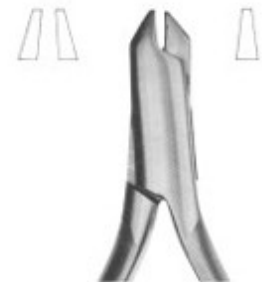

**2492**  
Aderer (Fig. 57)  
12 cm, 4 3/4"  
Wire & Clasp Bending Pliers



**2493**  
49 e 49 TC  
14 cm, 5 1/2"  
Band Removing Plier, short pad



**2494**  
50 e 50 TC  
14 cm, 5 1/2"  
Band Removing Plier, long pad



**2495**  
Fig. 84  
14.5 cm, 5 3/4"  
Band pinshing & ligature locking plier, serrated



**2496**  
Fig. 72  
14 cm, 5 1/2"  
Band pinshing & ligature locking plier, serrated



**2497**  
BRACKET (Fig. 82)  
13.5 cm, 5 1/4"  
Direct Bonding Bracket Remover



**2498**  
BRACKET (Fig. 82)  
13.5 cm, 5 1/4"  
Direct Bonding Bracket Remover

# Pliers for Orthodontic & Prosthetics



**2524**  
UNIVERSAL  
150 mm



**2525**  
WALDSACHS  
155 mm



**2526**  
ADERER  
125 mm



**2527**  
NANCE  
125 mm



**2528**  
REYNOLDS  
125 mm

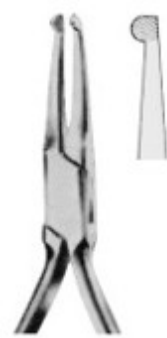

**2529**  
HOW  
145 mm



**2530**  
HOW  
140 mm



**2534**  
FURRER  
150 mm



**2531**  
WALDRON  
125 mm



**2532**  
ADAMS  
125 mm



**2533**  
ANGLE  
125 mm



**2535**  
YOUNG  
130 mm



**2536**  
NANCE  
130 mm

## Pliers for Orthodontic & Prosthetics



**2537**  
**LANGEBECK**  
 125 mm



**2538**  
**LANGEBECK**  
 140 mm



**2539**  
**LANGEBECK**  
 130 mm



**2540**  
**PEESO**  
 125 mm



**2541**  
**GOSLEE**  
 125 mm



**2542**  
**FISCHER**  
 140 mm



**2543**  
**FISCHER**  
 140 mm



**2544**  
**JOHNSON**  
 130 mm



**2545**  
**MSY**  
 130 mm



**2546**  
**MC KELLOPS**  
 155 mm



**2547**  
**ANDRESEN**  
 130 mm



**2548**  
**SCHWARZ**  
 130 mm



# Rongeurs

Ahmed Pak Impex



**2549**  
BLUMENTHAL  
6", 30°, Standard

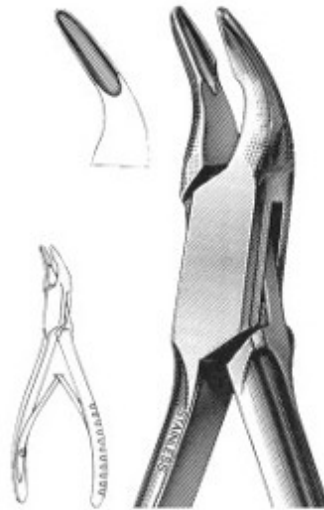

**2550**  
MINI-BLUMENTHAL  
6", 45°

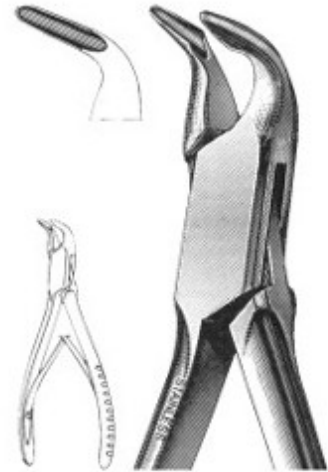

**2551**  
MINI-BLUMENTHAL  
6", 90°

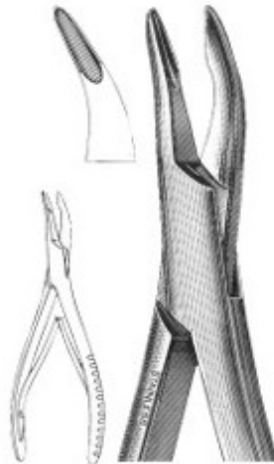

**2552**  
BLUMENTHAL  
7", 30°

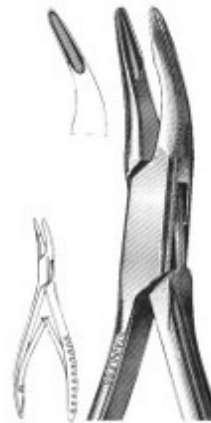

**2553**  
MINI-BLUMENTHAL  
4 1/2", 30°

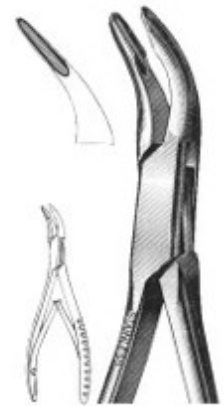

**2554**  
MINI-BLUMENTHAL  
4 1/2", 45°





# Rongeurs

Ahmed Pak Impex



**2555**  
CLEVELAND  
No. 5-Side Cutting,  
6 3/4"

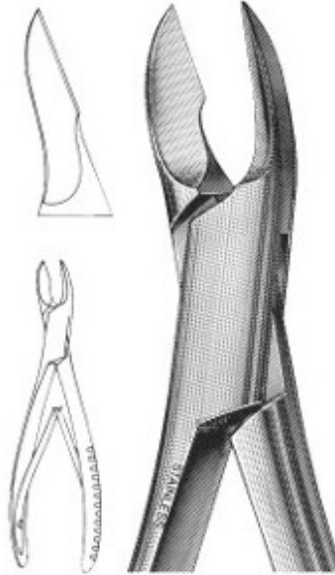

**2556**  
CLEVELAND  
No. 5A-Side Cutting,  
6 1/2"

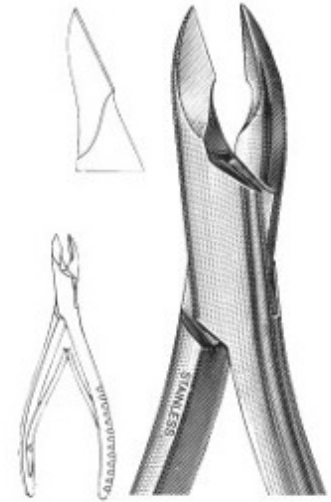

**2557**  
CLEVELAND  
No. 5S-Side Cutting,  
6"

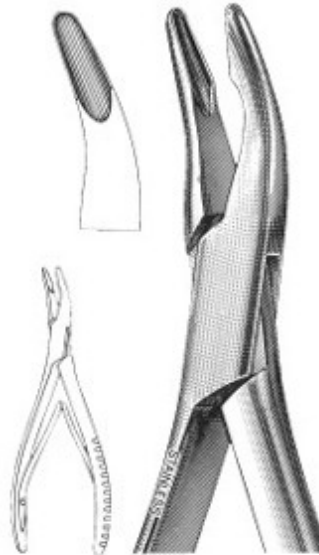

**2558**  
No. 1A-MEAD  
6 1/2"

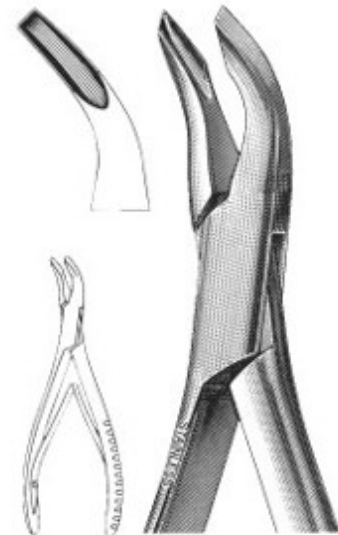

**2559**  
MEAD, Square  
No. 2A  
Tips, 6 1/2"



# Rongeurs

Ahmed Pak Impex



**2560**  
FRIEDMAN  
5 1/2"

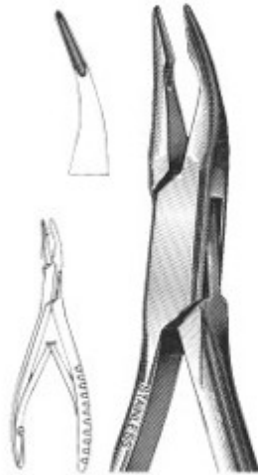

**2561**  
MICRO-FRIEDMAN  
5 1/2", 15° Curved Jaws



**2562**  
MICRO-FRIEDMAN  
Perio Rongeur, 5 1/2"

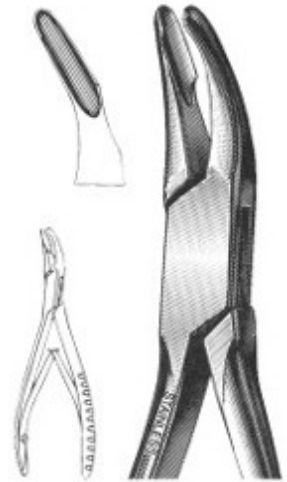

**2563**  
CLEVELAND  
No. 4 - 5 1/2"

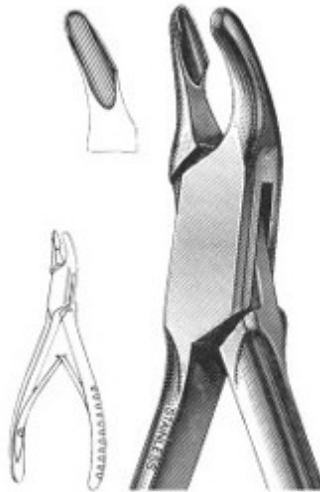

**2564**  
CLEVELAND  
No. 4A - 6 1/2"

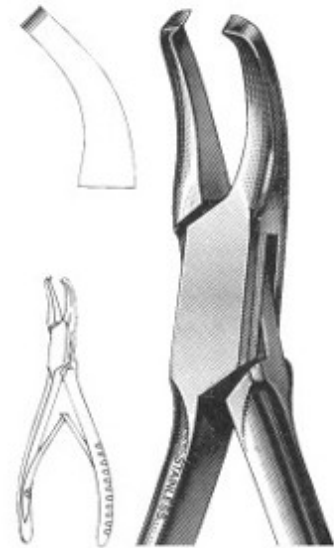

**2565**  
GARDNER  
No. 6A, End Cutting  
6 1/2"



# Rongeurs

Ahmed Pak Impex



**2566**  
BEYER  
Double Action,  
16,18 cm



**2567**  
No. 1  
6 1/2"

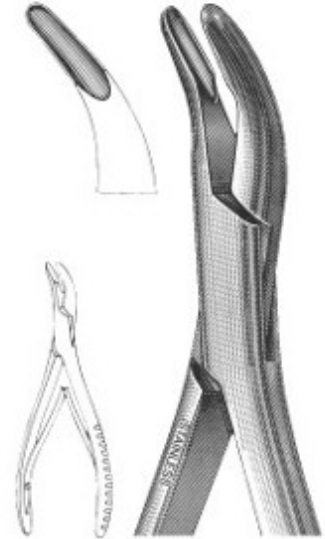

**2568**  
HARTMAN  
5 3/4"  
Strong Curve



**2569**  
BANE  
Slight Curve  
7"



## Needle Holders

Ahmed Pak Impex



**2570**  
COLLIER  
5", Fenestrated Jaws



**2571**  
DERF  
4 3/4"



**2572**  
WEBSTER  
Delicate Smooth Jaws  
5"



**2573**  
NEIVERT  
One Offset Ring  
5"



**2574**  
OLSEN-HEGAR  
5 1/2"



**2575**  
BAUMGARTNER  
5 1/2"



**2576**  
CRILE-WOOD  
6"



**2577**  
GARDNER  
5"



Ahmed Pak Impex

# Needle Holders



**2578**  
MAYO-HEGAR  
5"



**2579**  
CRILE  
6"



**2580**  
CASTROVIEJO  
Smooth Jaws  
5 1/2"



**2581**  
BOYNTON  
5"



**2582**  
MATHIEU  
5 1/2"



**2583**  
STEVENS  
6 1/2"



# Micro Surgery Set

Ahmed Pak Impex



**2584**  
Micro Scissor  
Straight, 155 mm



**2585**  
Micro Scissor  
Straight, 150 mm



**2586**  
Micro Scissor  
Curved, 150 mm



**2587**  
Micro Scissor  
Curved, 155 mm



**2588**  
CASTROVIEJO  
T.C.  
Straight, 180 mm



**2589**  
Retractor  
Fig.3  
165 mm



**2590**  
Micro Adson  
120 mm



**2591**  
GERALD  
Curved,



**2592**  
GERALD  
Straight,



**2593**  
Micro Adson  
160 mm



**2594**  
Micro Surgery Set 10 Pieces.



# Scissors

Ahmed Pak Impex

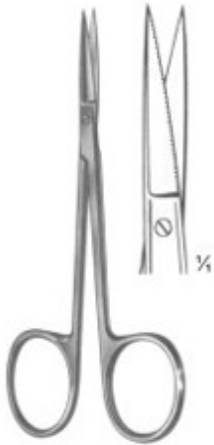

**2595**  
IRIS (Standard)  
Straight  
11.5 cm, 4 1/2"

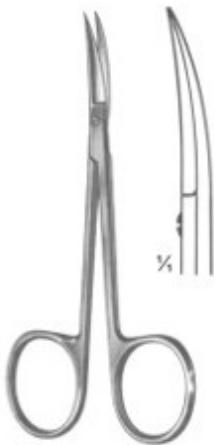

**2596**  
IRIS (Standard)  
Curved  
11.5 cm, 4 1/2"

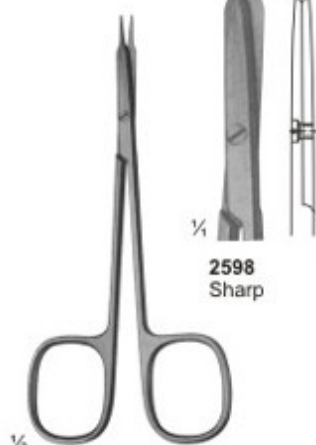

**2597**  
STEVENS  
Dissecting Scissors  
Size: 115 mm



**2598**  
Sharp



**2599**  
Sharp



**2600**  
Blunt



**2601**  
Blunt



**2602**  
JOSEPH  
Size: 150 mm

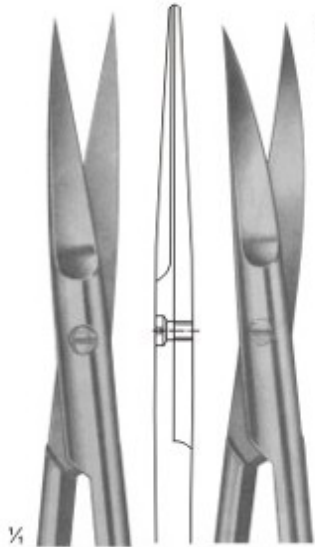

**2603**

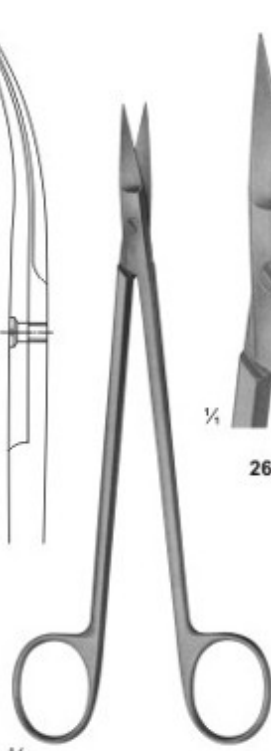

**2604**  
KELLY  
Size: 175 mm



**2605**

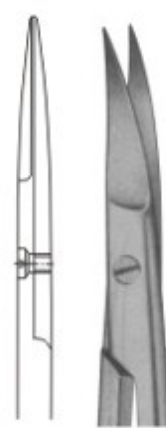

**2606**



**2607**  
QUINBY  
Size: 130 mm



# Scissors

Ahmed Pak Impex

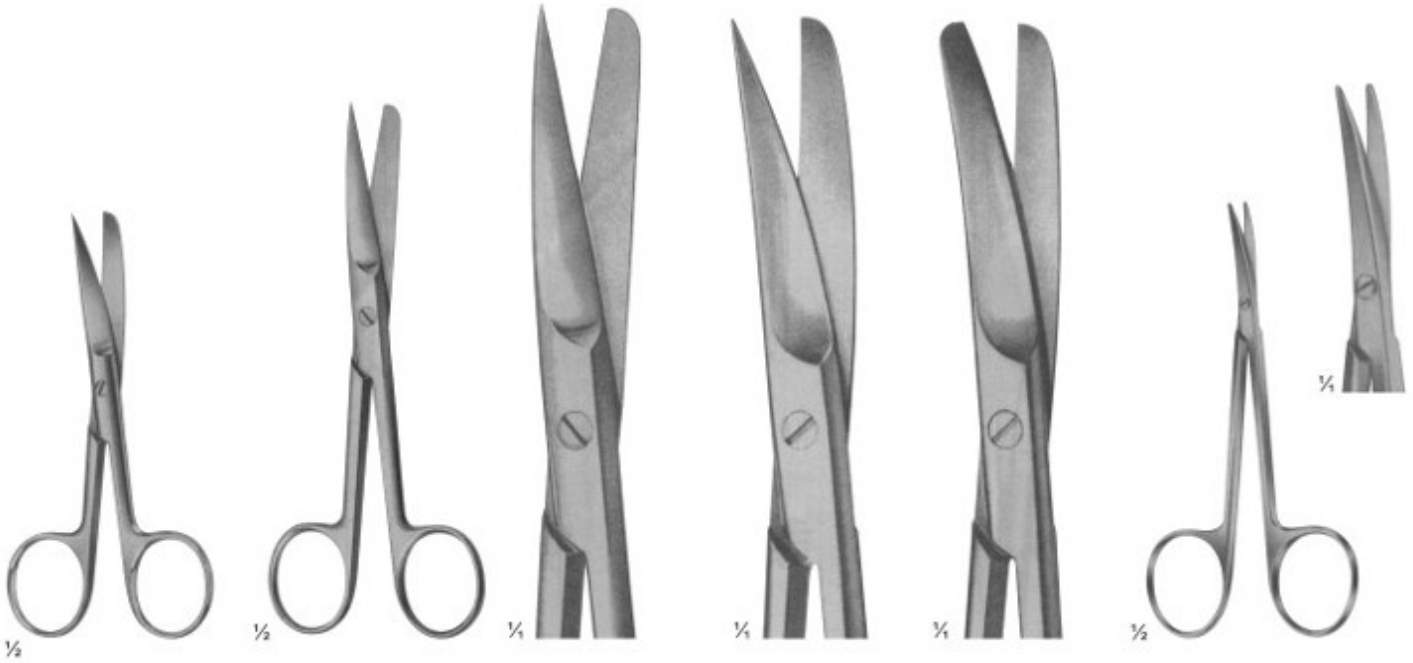

**2608**  
Standard - Types  
Size: 115 mm

**2609**  
DEEVER  
With flat lock

**2610**  
Size: 145 mm

**2611**  
Size: 145 mm

**2612**  
Size: 145 mm

**2613**  
LITTLER  
Dissecting Scissors  
Size: 115 mm

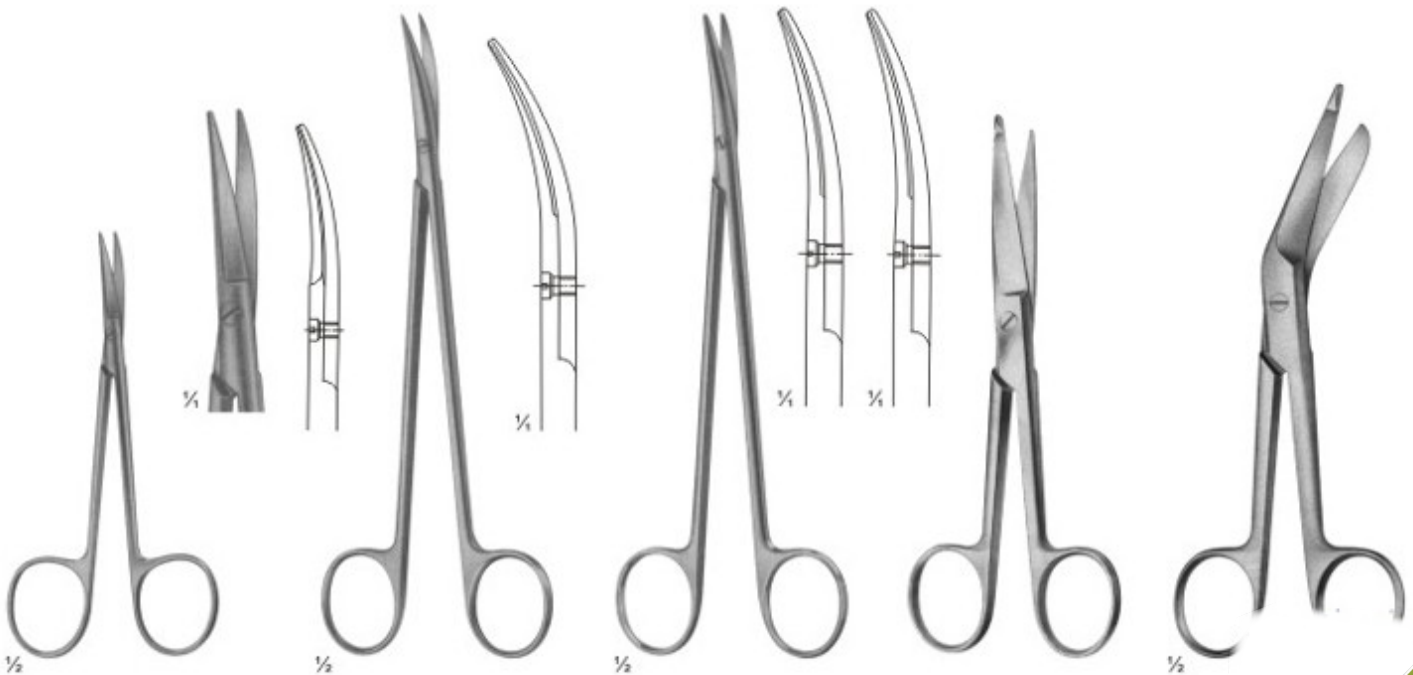

**2614**  
COTTLE  
Bulldog Scissors  
Size: 115 mm

**2615**  
DE BAKEY  
Ateriotomy scissors  
Size: 175 mm

**2616**  
TOENNIS - ADSON  
Dissecting scissors  
Size: 175 mm

**2617**  
KNOWLES  
Size: 145 mm





# Scissors

Ahmed Pak Impex

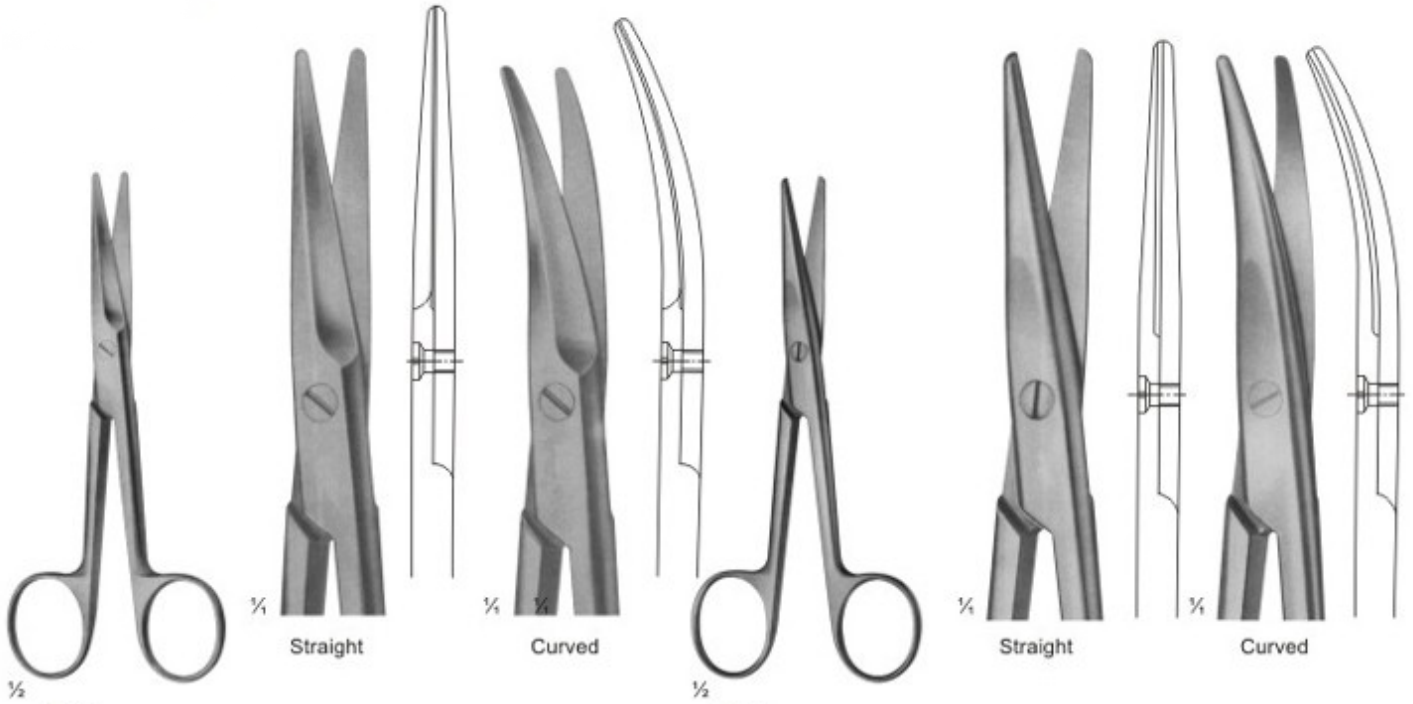

**2619**  
MAYO (straight)  
Size: 140 mm

**2620**  
MAYO-STILLE (straight)  
Size: 140 mm

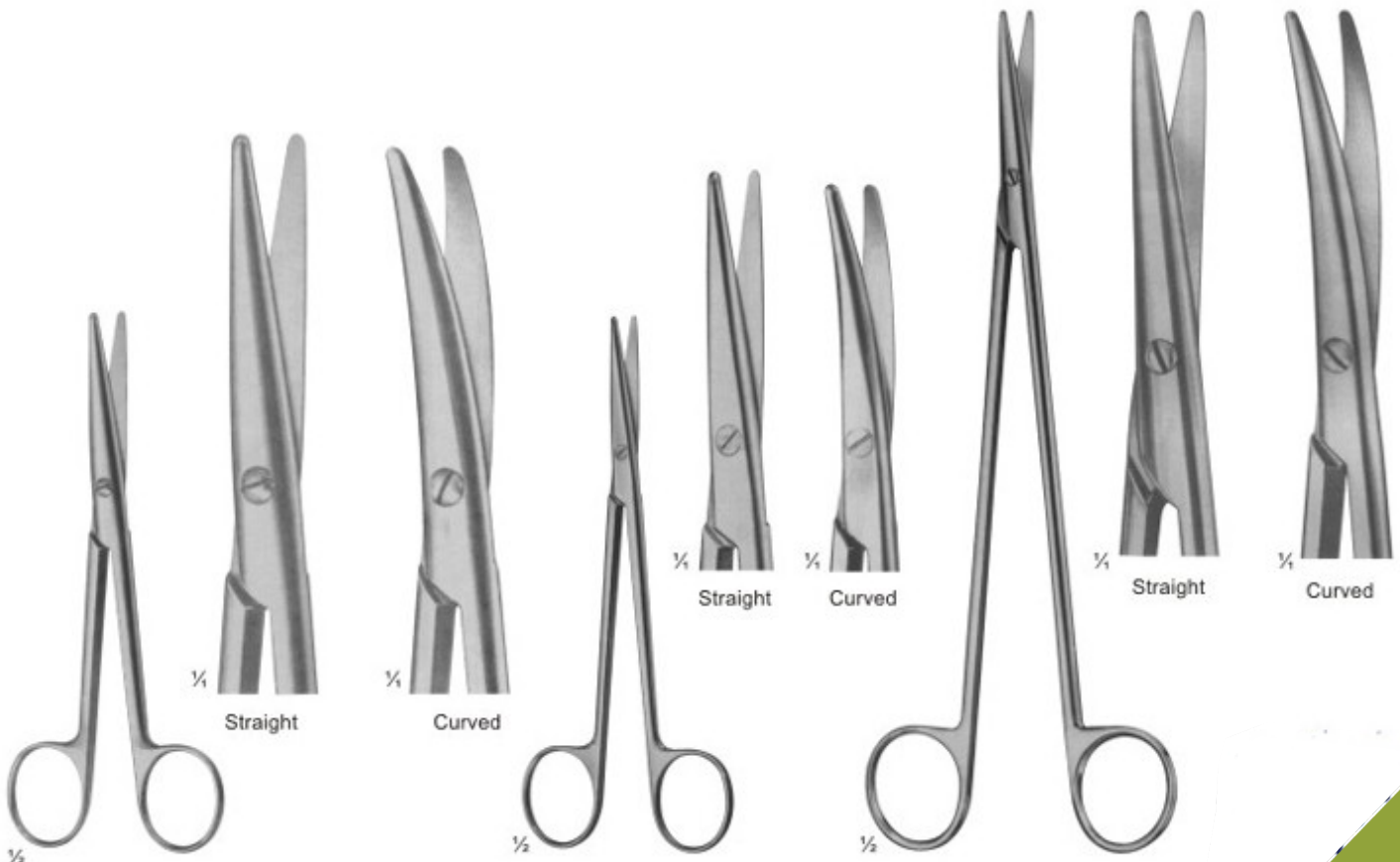

**2621**  
STILL F

**2622**  
MFT7FNRAUM

**2623**  
NFI SON-MFT7FNRAUM



# Scissors

Ahmed Pak Impex

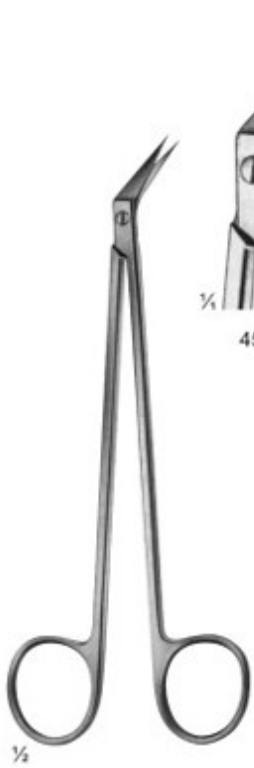

**2624**  
DE BAKEY  
Size: 155 mm



**2625**  
LOCKLIN  
Curved Sideways,  
1 Toothed Blade  
Size: 155 mm



**2626**  
SPENCER  
Size: 90 mm

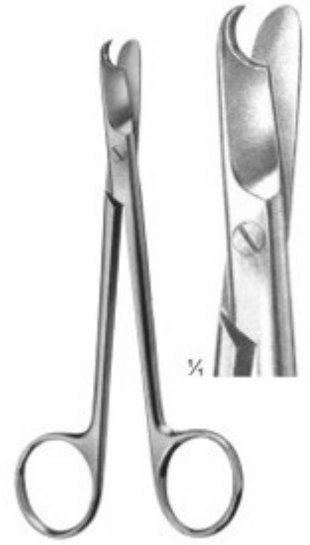

**2627**  
LITTAUER  
Size: 135 mm



**2628**  
BEEBE  
Size: 110 mm

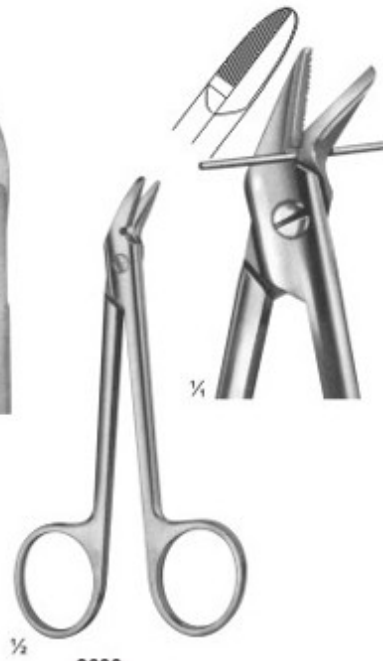
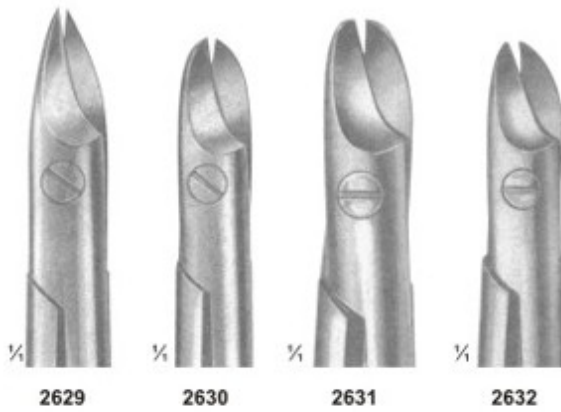

**2633**  
1 Blade Serrated  
Size: 120 mm

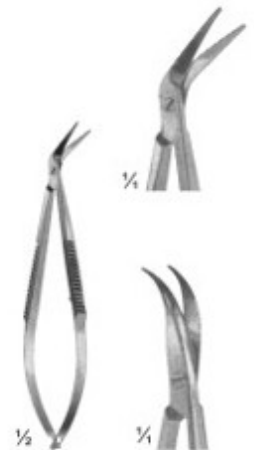

**2634**  
CASTROVIEJO  
Size: 90 mm

# Impression Trays

Made of 18/8 Stainless Steel, Solid, Set of 10

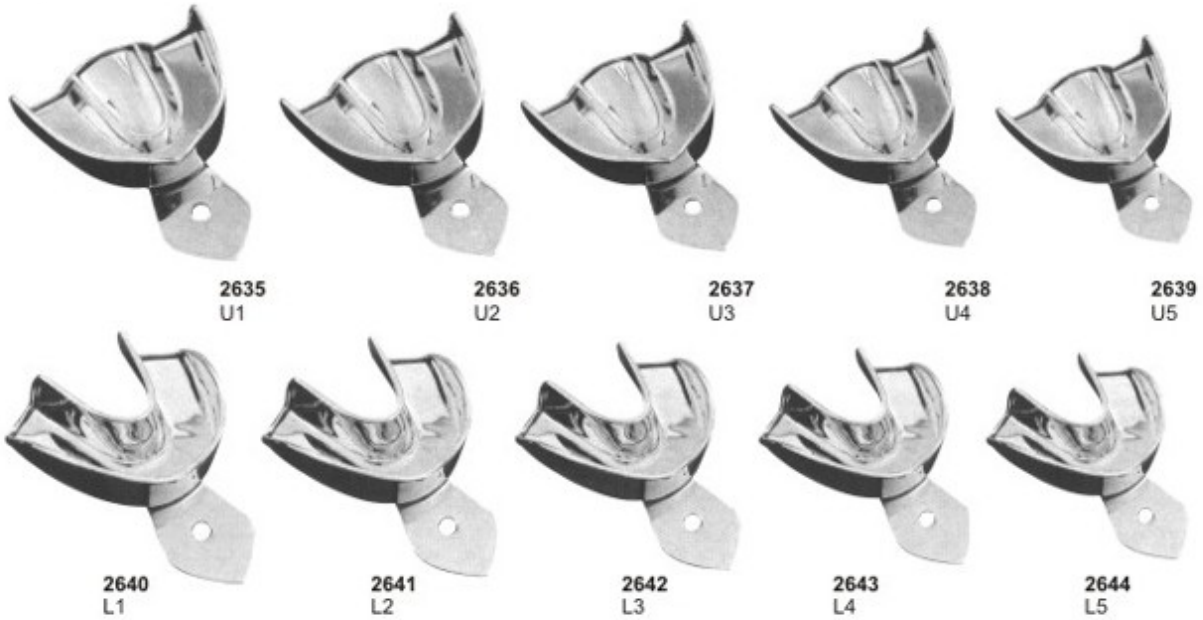

All The Above Impression Trays are Available in These 5 Sizes

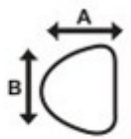

| UPPER | U1 | U2 | U3 | U4 | U5 |
|-------|----|----|----|----|----|
|       | A  | 62 | 60 | 53 | 54 |
| B     | 83 | 75 | 73 | 69 | 68 |

All Dimension are in mm

| LOWER | L1 | L2 | L3 | L4 | L5 |
|-------|----|----|----|----|----|
|       | A  | 63 | 61 | 57 | 60 |
| B     | 82 | 81 | 78 | 74 | 71 |

All Dimension are in mm

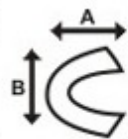

## Perforated, Set of 10

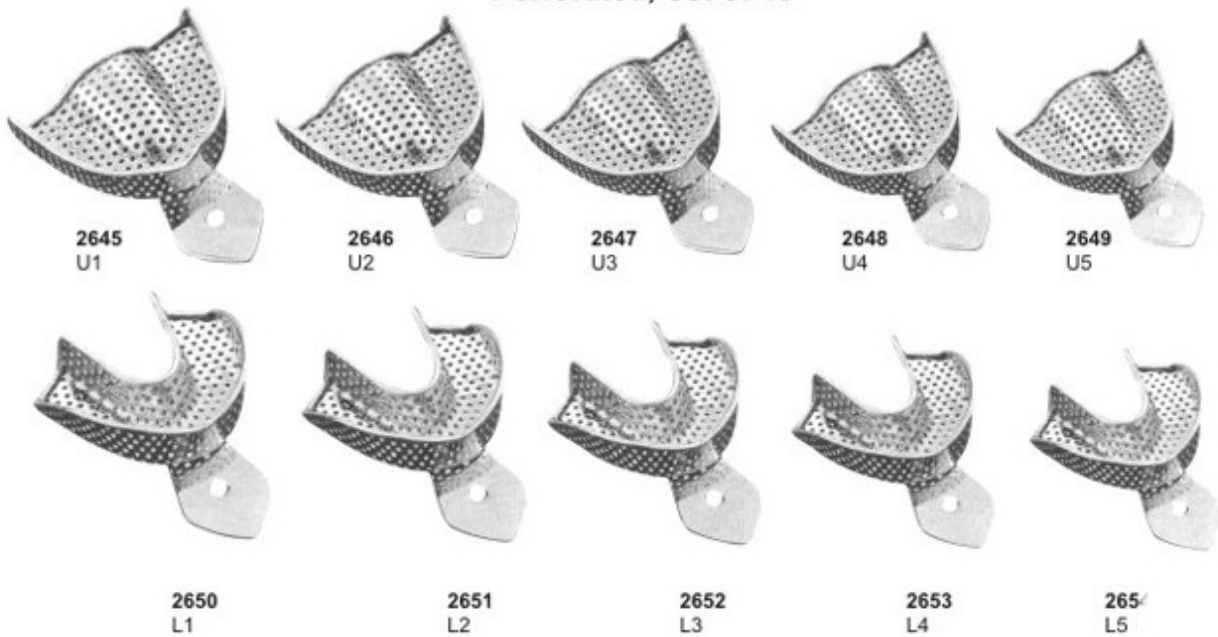

# Impression Trays

Made of 18/8 Stainless Steel, Solid Full Denture Set of 8

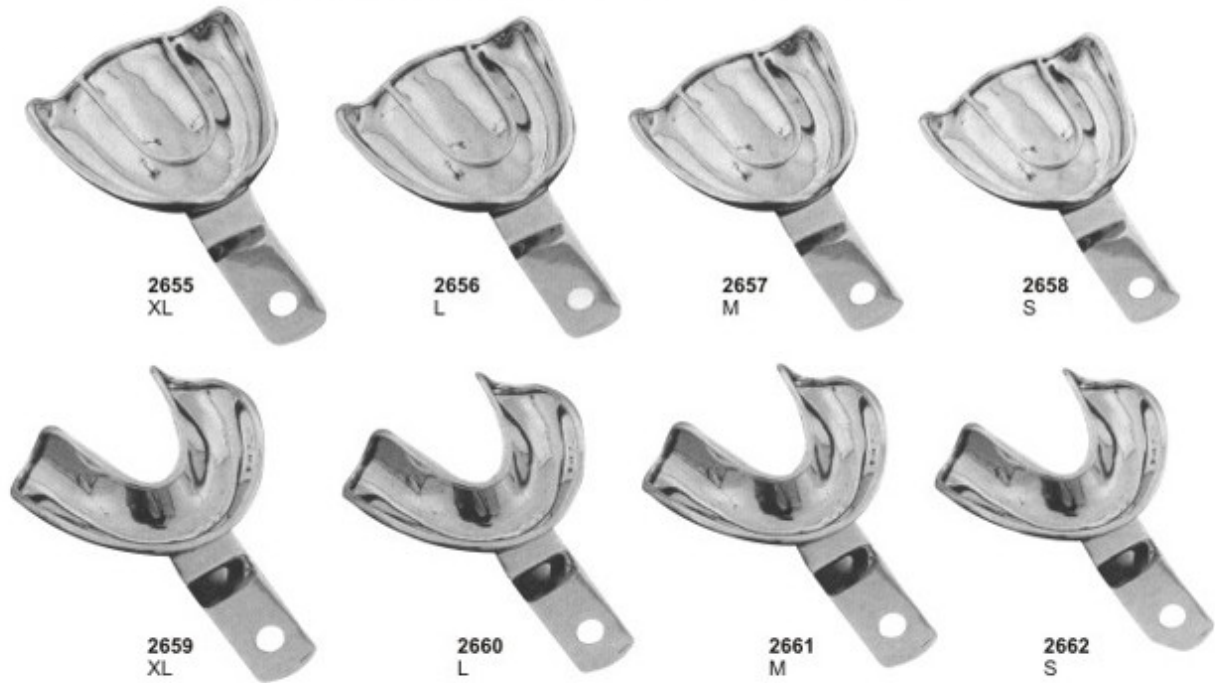

All The Above Impression Trays are Available in These 4 Sizes

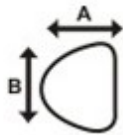

| UPPER |    | XL | L  | M  | S  |
|-------|----|----|----|----|----|
|       | A  | 70 | 67 | 64 | 60 |
| B     | 79 | 76 | 70 | 73 |    |

All Dimension are in mm

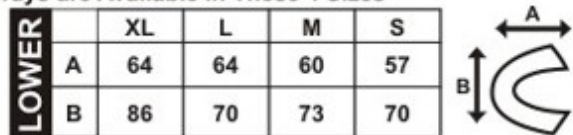

| LOWER |    | XL | L  | M  | S  |
|-------|----|----|----|----|----|
|       | A  | 64 | 64 | 60 | 57 |
| B     | 86 | 70 | 73 | 70 |    |

All Dimension are in mm

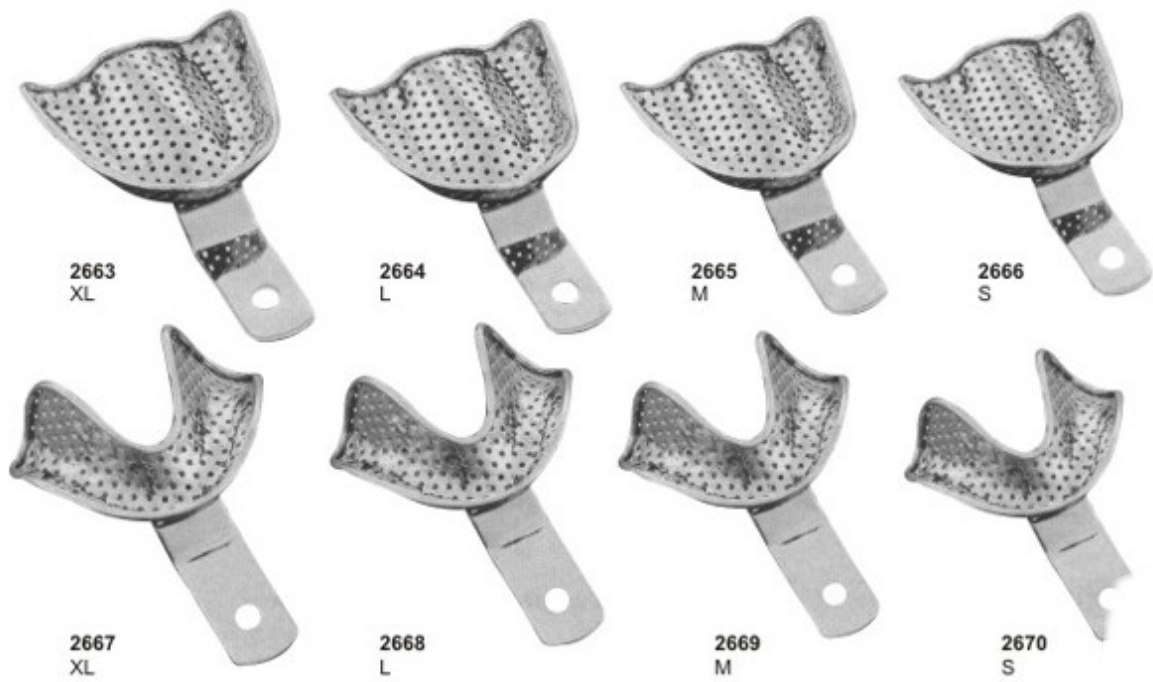

Perforated Full Denture Set of 8

# Impression Trays

Made of 18/8 Stainless Steel, Solid Set of 6

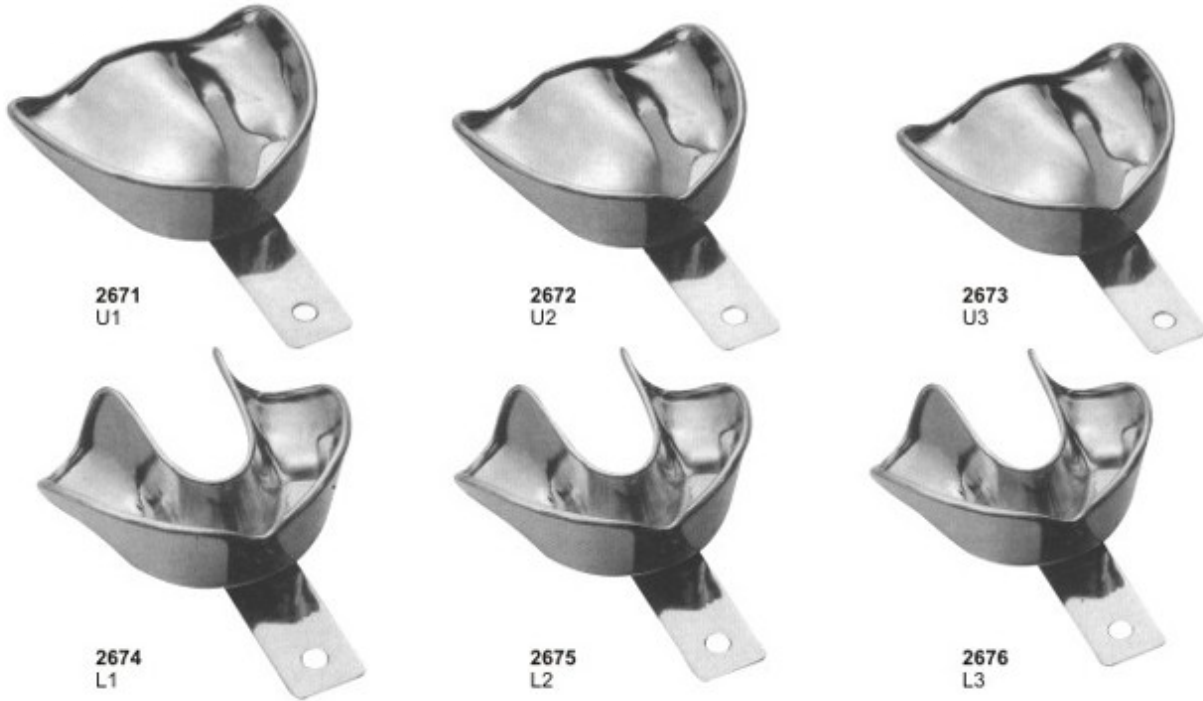

All The Above Impression Trays are Available in These 4 Sizes

| UPPER |    | U1 | U2 | U3 | LOWER |    | L1 | L2 | L3 |
|-------|----|----|----|----|-------|----|----|----|----|
|       | A  | 67 | 64 | 57 |       | A  | 60 | 57 | 54 |
| B     | 81 | 71 | 70 | B  | 81    | 79 | 76 |    |    |

All Dimension are in mm

All Dimension are in mm

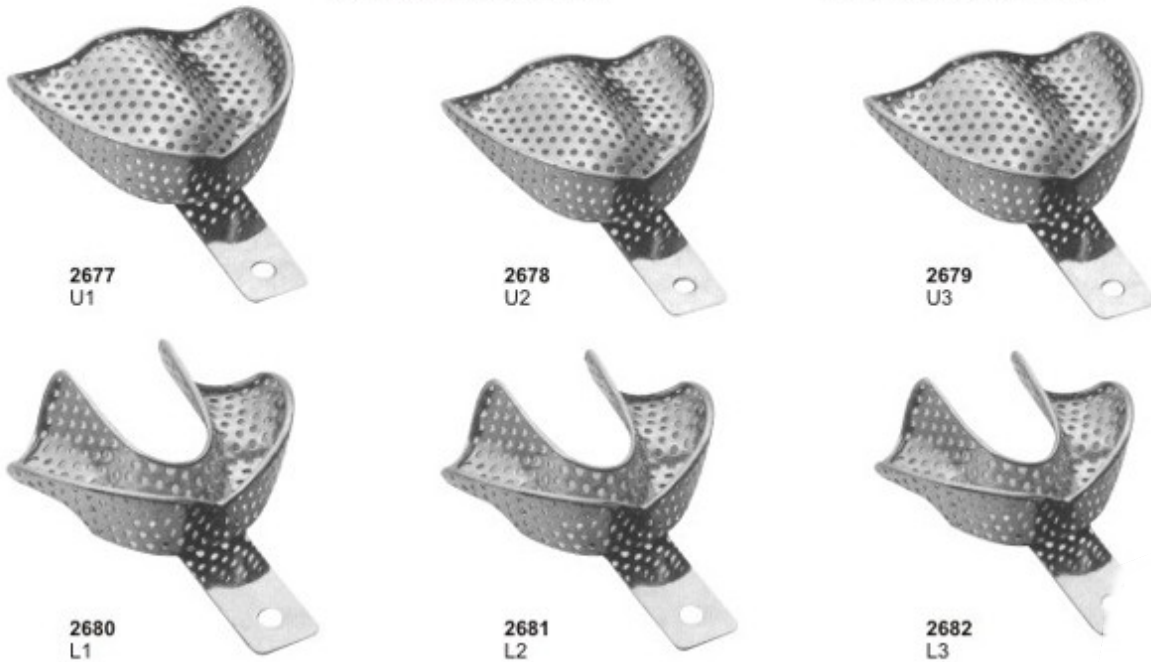

Perforated Set of 6

# Impression Trays

Made of 18/8 Stainless Steel, English Pattern Set of 8



2683  
Lower



2684  
Upper

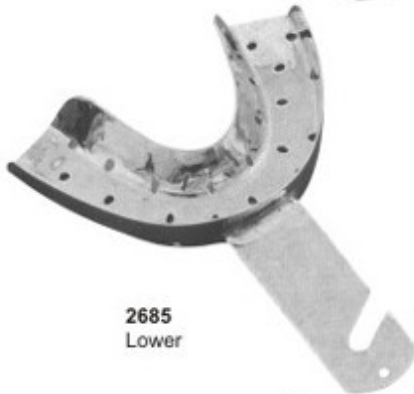

2685  
Lower



2686  
Upper



2687  
Lower



2688  
Upper

All The Above Impression Trays are Available in These 4 Sizes

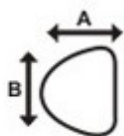

| <b>UPPER</b> | Size | A  | B  | C  |
|--------------|------|----|----|----|
|              | 0    | 67 | 50 | 12 |
|              | 1    | 72 | 51 | 13 |
|              | 2    | 78 | 55 | 15 |
|              | 3    | 80 | 58 | 15 |

All Dimension are in mm

| <b>LOWER</b> | Size | A  | B  | C  |
|--------------|------|----|----|----|
|              | 0    | 70 | 50 | 14 |
|              | 1    | 77 | 51 | 15 |
|              | 2    | 79 | 55 | 15 |
|              | 3    | 80 | 60 | 17 |

All Dimension are in mm

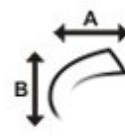

# Impression Trays

Made of 18/8 Stainless Steel, Solid Full Denture Set of 8



All The Above Impression Trays are Available in These 4 Sizes

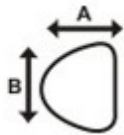

| UPPER |    | XL | L  | M  | S  |
|-------|----|----|----|----|----|
|       | A  | 70 | 67 | 64 | 60 |
| B     | 79 | 76 | 70 | 73 |    |

All Dimension are in mm

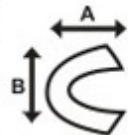

| LOWER |    | XL | L  | M  | S  |
|-------|----|----|----|----|----|
|       | A  | 64 | 64 | 60 | 57 |
| B     | 86 | 70 | 73 | 70 |    |

All Dimension are in mm

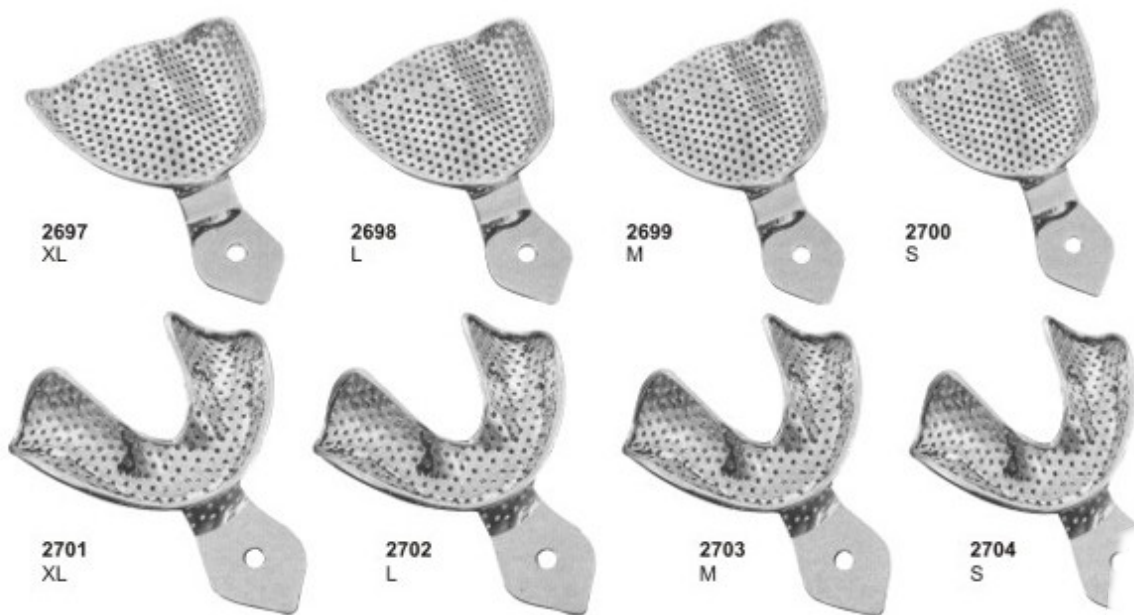

Made of 18/8 Stainless Steel, Perforated Full Denture Set of 8



# Impression Trays

Ahmed Pak Impex

Made of 18/8 Stainless Steel, Solid Full Denture Set of 8

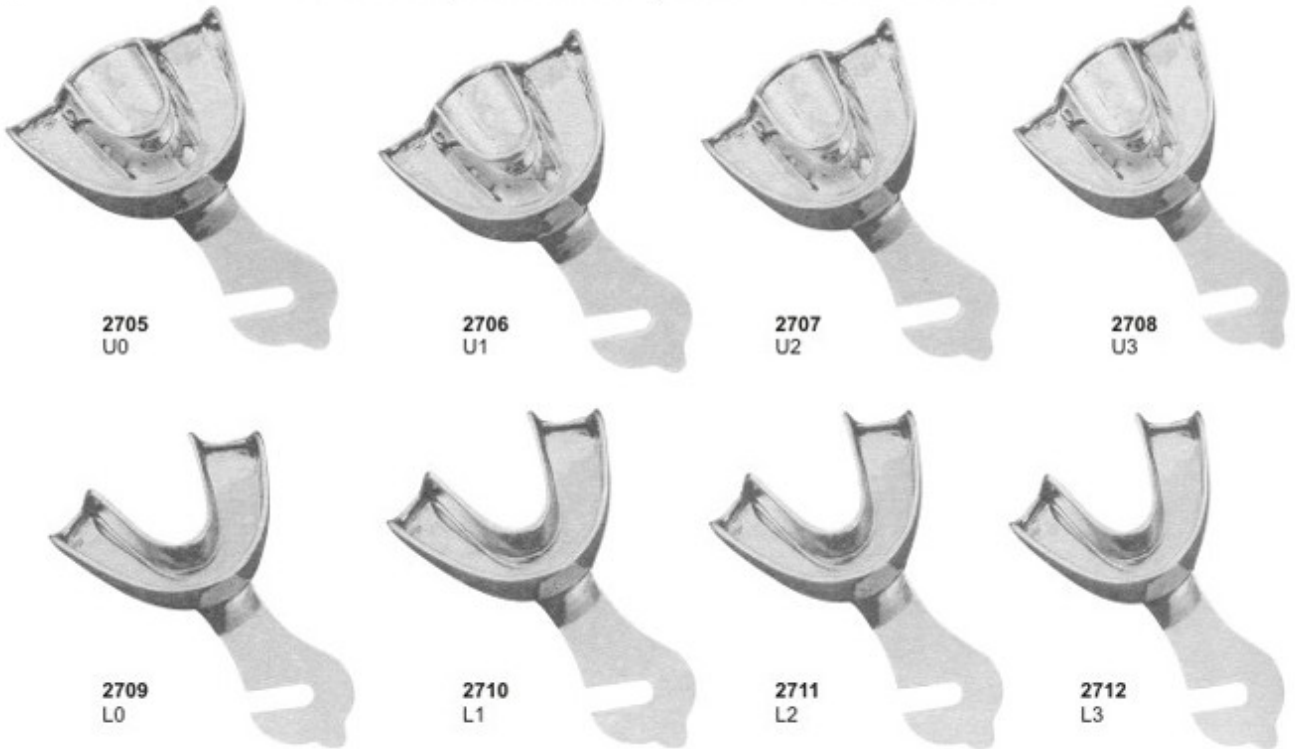

Upper Sizes: 0,1,2,3

Depth of Tray: 15,9 mm, Height of Plate: 12,5 mm

Lower Sizes: 0,1,2,3

Depth of Tray: 12,9 mm

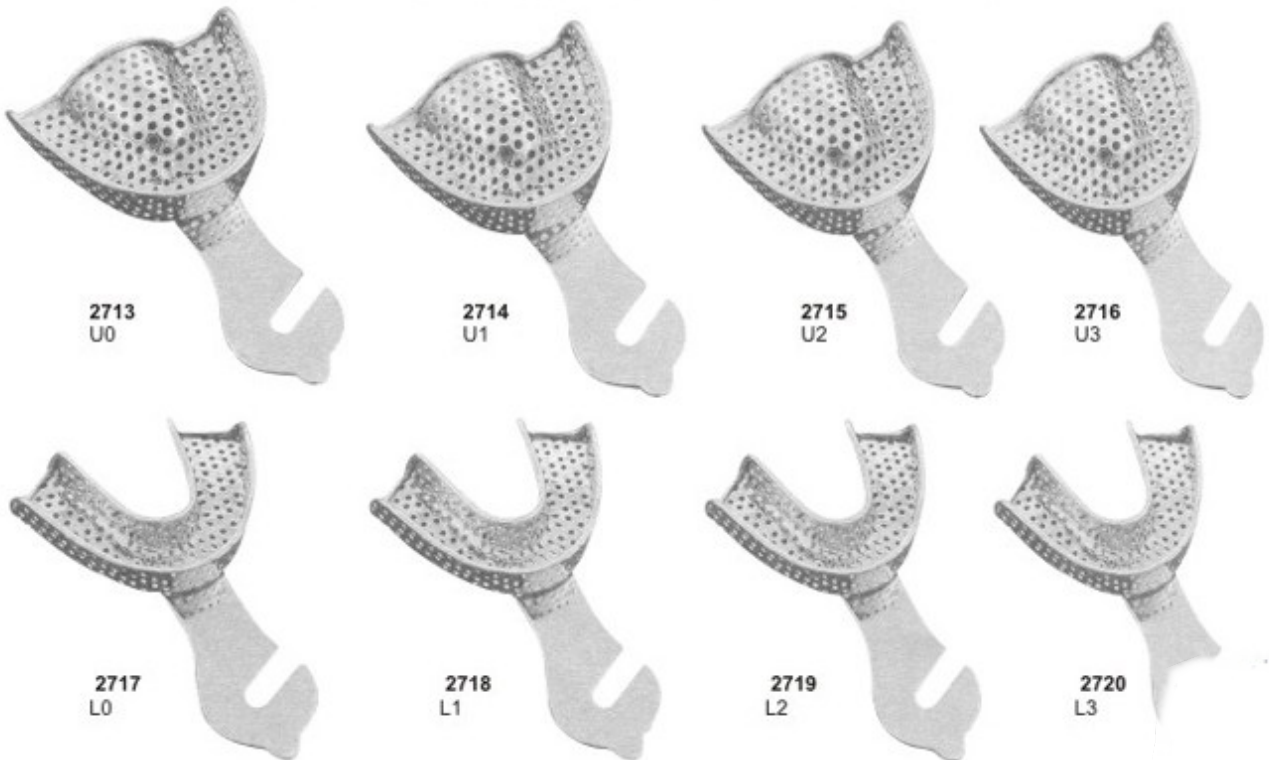

Made of 18/8 Stainless Steel, Perforated Full Denture Set of 8



# Impression Trays

## Impression Trays For Crown & Bridge Work

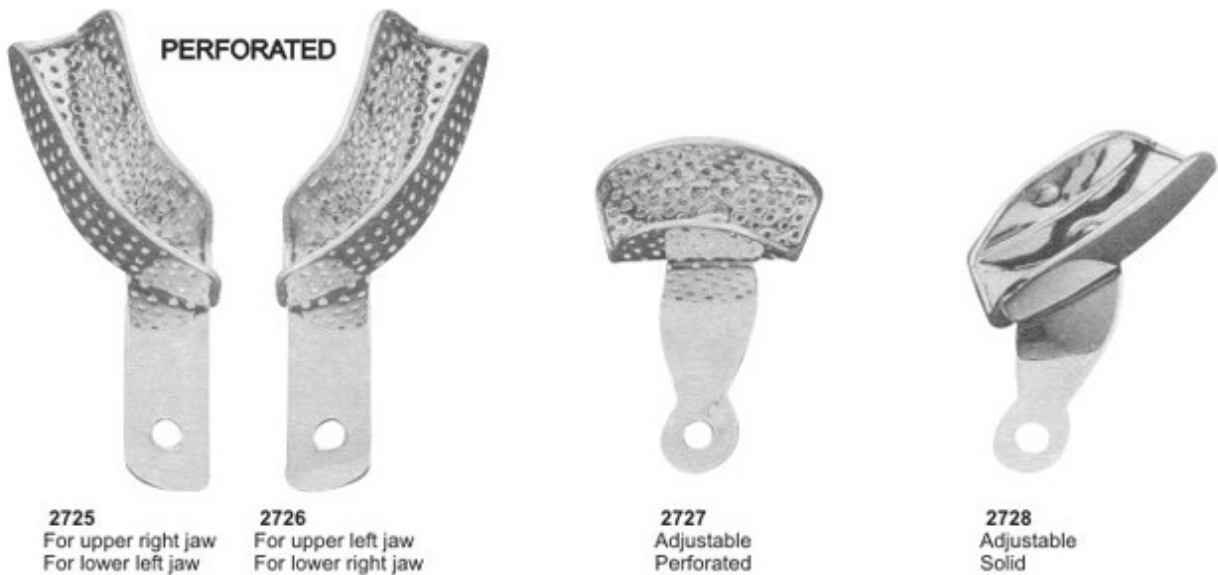
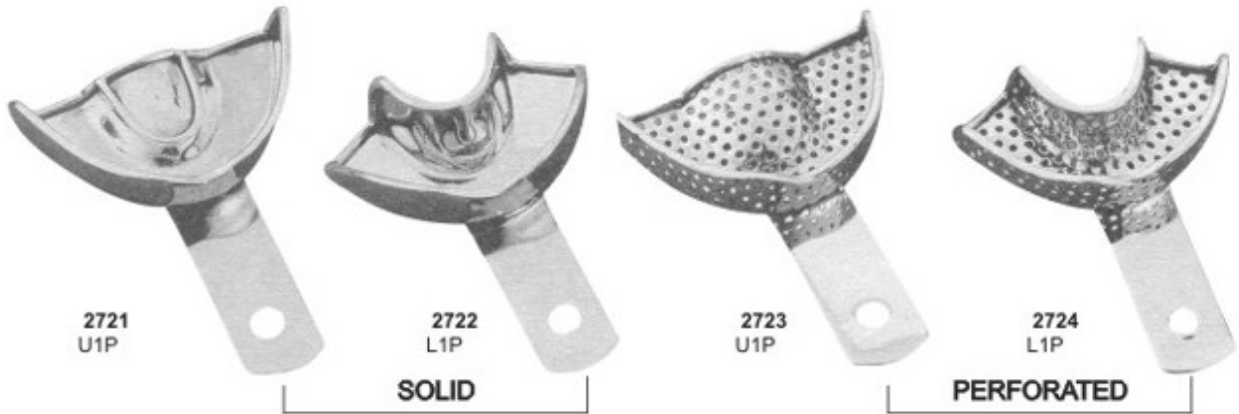

**Available in 4 sizes**

- 1.....44 mm
- 2.....55 mm
- 3.....60 mm
- 4.....65 mm



# Articulators

Ahmed Pak Impex



2729



2730



2731



2732



2734



2733

# Articulators

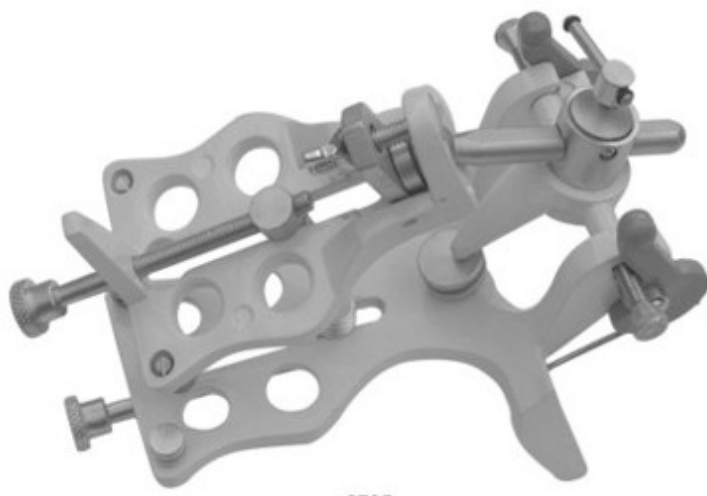

2735



2736



2737



2738



2739



2740



2741



2742

# Hollow Wares



**2743**  
Instruments Tray



**2743**  
Instruments Tray



**2744**  
Instruments Tray



**2744**  
Instruments Tray

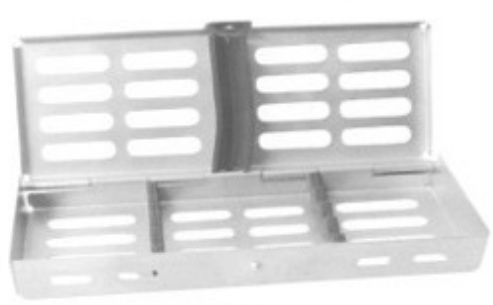

**2745**  
Instruments Tray



**2745**  
Instruments Tray



**2746**  
Instruments Tray  
Perforated



**2747**  
Instruments Tray  
Perforated Base



**2748**  
Instruments Tray  
Solid Base

# Hollow Wares



**2749**  
Pulpectomy Tray



**2750**  
Sterilizing Box  
Available Sizes:  
17x17x3 cm  
20x10x6 cm  
30x14x6 cm



**2751**  
Endo Tray Box



**2752**  
Bucket With Handle & Lid  
Stainlss Steel 18/10  
Capacity:  
6. Liter  
10. Liter  
12. Liter  
15. Liter

**2753**  
Sterilizing Drum  
150x150mm  
175x175mm  
190x190mm  
200x140mm  
200x200mm  
240x120mm  
225x225mm  
240x240mm  
290x160mm



**2754**  
Sterilizing Drum  
280x240mm  
230x150mm  
300x250mm  
340x160mm  
350x250mm  
390x200mm  
380x300mm  
100x100mm  
150x120mm

# Sterilizing Boxes & Instruments Trays



**2755**  
Instruments Box



**2756**  
Instruments Box



**2757**  
Instruments Box



**2758**  
Instruments Sterilizer  
150x75 mm



**2759**  
Endodontic Box



**2760**  
Sterilizing Box  
320x120 mm



**2761**  
Instruments Tray



**2762**  
Instruments Tray



**2763**  
Instruments Tray  
(Perforated)



**2764**  
Instruments Tray  
Shallow(Mayo)



**2765**  
Scalers Tray



**2766**  
Scalers Tray

# Hollow Wares



2767      2768      2769      2770  
**Forcep and Thermometer Jars**



2771  
**Cotton Holding Jar**  
 60x50 mm



2772  
**Spitten Mug**



2773  
**Spirit Burner With Wick**  
 Stainless Steel 18/10  
 Capacity: 150 ml, 60 ml



2774  
**Spirit Burners With Wick**  
 Stainless Steel 18/10  
 Capacity: 70ml



2775  
**Dressing Jar**



2776  
**Dressing Jar**



2777  
**Irrigator(Douch Can)**



2778  
**Measuring**



## Hollow Wares

Ahmed Pak Impex



**2779**  
Gallipot



**2780**  
Medicine Cup



**2781**  
Funnel 100 mm



**2782**  
Tube Rack, Round Model  
Stainless Steel 18/10



**2783**  
Tube Rack, Stainless Steel 18/10



**2784**  
Bed Pan (Perfection) Type Child  
With & Without Cover 300 mm



**2785**  
Bed Pan (Type French)  
430 mm

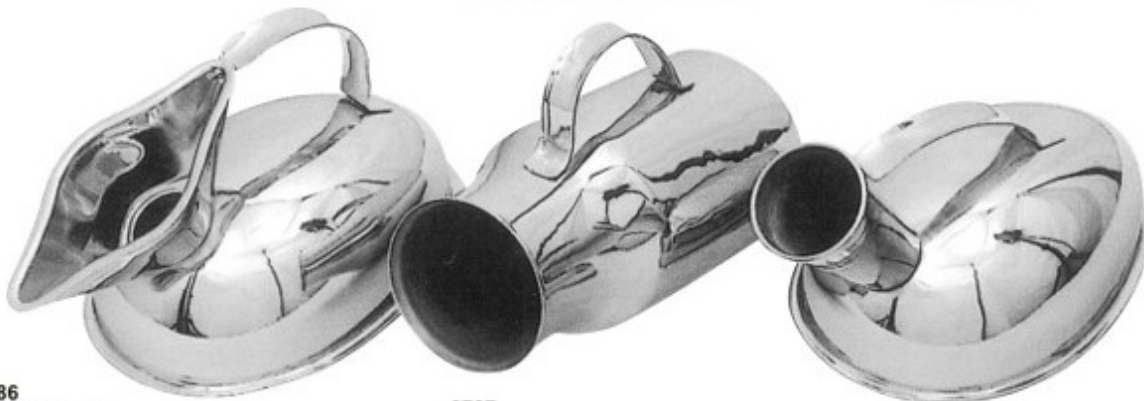

**2786**  
Urinals Female  
( 1 Piece )Capacity 0.75 Ltr

**2787**  
Urinals Male  
Capacity 1 Ltr

**2788**  
Urinals Male  
Capacity 0.75 Ltr



**2789**  
Bed Pan Hand Made  
Adult / Child



**2790**  
Bed Pan (Type Sleeper)  
With & Without Cover  
Child 300 mm / Adult 350 mm



**2791**  
Bed Pan (Type Round)  
300 x 85 mm



# Hollow Wares



**2792**  
Sponge Bowl



**2794**  
Wash Basin  
300mm-350mm-400mm



**2795**  
Kick Bucket With Trolley



**2793**  
Sponge Bowl



**2796**  
Kidney Tray Shallow  
150mm-200mm-240mm-300mm



**2797**  
Kidney Tray Without Lid  
150mm-200mm-250mm-300mm



**2798**  
Kidney Tray With Lid  
150mm-200mm-250mm-300mm



**2799**  
Dustbin Without Stand



**2800**  
Dustbin Without Stand & Cap



**2801**  
Needle Case Rectangle  
Needle Case Round With Cover  
90x15



**2802**  
Lotion Bowl With Lip



*Ahmed Pak Impex*

## CONTACT US

### PAKISTAN OFFICE

AHMED BUILDING  
SAMINAR ROAD, NEKA PURA,  
SIALKOT 51310 PAKISTAN.  
+92 321 7131515  
Info@ahmedpak.com  
zee.ahmedpak@gmail.com  
www.ahmedpak.com

### DUBAI OFFICE

HAMARIYA FREE ZONE, SHARJAH,  
U.A.E.  
+91 154 7263687  
Info@ahmedpak.com  
zee.ahmedpak@gmail.com  
www.ahmedpak.com